

Input Parameters

NOMINAL INPUT VOLTAGE RANGE	100 - 240VAC
MAX. INPUT VOLTAGE RANGE	90-264VAC
INPUT FREQUENCY	47-63Hz
MAXIMUM INPUT CURRENT	8.5AAC
INRUSH CURRENT	<40 AMPS

Output Parameters

Adjustment and Derating.

The Vega 450 series is designed to provide a max output power of 450W at nominal output voltages. The following procedure must be used to ensure the PSU is operated within its ratings.

- Calculate user power for each module (volts x amps).
- Add all the individual module powers together. The total power must not exceed the value given.
- Calculate secondary transformer turns x amps for each module. See the outputs table for transformer secondary turns.
- Add all the module turns x amps together and this must not exceed the ampere turns.
- If necessary reduce the loading until the conditions are met, ie. power and ampere-turns maxima.

Cooling Option	Max Ambient	Dual Width Modules Fitted	Max Total Power	Max Total Ampere Turns (AT)	Special AT Limit **	Module Current Rating
FD (Standard or Ruggedised* Fan - Forward Airflow)	50	No	450	180	-	100%
		Yes	450	180	180	100%
R,E (Standard or Ruggedised* Fan - Reverse Airflow)	45	No	450	180	-	100%
		Yes	450	180	158	90%
	50	No	440	176	-	100%
		Yes	420	180	158	90%
Q (Quiet Fan - Forward Airflow)	50	No	450	180	-	100%
P (Quiet Fan - Reverse Airflow)	40	No	440	176	-	100%
		Yes	450	180	152	85%
	45	No	400	160	-	100%
		Yes	420	180	152	85%
	50	No	350	140	-	100%
		Yes	370	180	143	85%
C (Customer Air Option)	50	see following detail				

* Ruggedised fan (papst 622HH, not for use in PSUs fitted with IEC inlet).

** For products with dual width modules the following rules apply:

One Dual Width module:

Total Ampere turns for modules in slots 1 to 4 must be < the value shown in Special AT Limit column.

Total Ampere turns for modules in slots 2 to 5 must be < the value shown in Special AT Limit column.

Two Dual Width modules:

Total Ampere turns for modules in slots 1 to 3 must be < the value shown in Special AT Limit column.

Total Ampere turns for modules in slots 2 to 5 must be < the value shown in Special AT Limit column.

Customer Air Cooling (option C):

The following method must be used for determining the safe operation of PSUs when C option (Customer Air) is fitted, ie fan not fitted to PSU.

For PSUs cooled by customer supplied airflow the components listed in the following table must not exceed the temperatures given. Additionally ratings specified for units with an internal fan must still be complied with, eg mains input voltage range, maximum output power, ampere turns, module voltage / current ratings and maximum ambient temperature. To determine the component temperatures the heating tests must be conducted in accordance with the requirements of IEC/EN/UL/CSA60950-1 Clause 4.5. Consideration should also be given to the requirements of other safety standards.

Test requirements include: PSU to be fitted in its end-use equipment and operated under the most adverse conditions permitted in the end-use equipment handbook/specification and which will result in the highest temperatures in the PSU. To determine the most adverse conditions consideration should be given to the end use equipment maximum operating ambient, the PSU loading and input voltage, ventilation, end use equipment orientation, the position of doors & covers, etc. Temperatures should be monitored using type K fine wire thermocouples (secured with cyanoacrylate adhesive, or similar) placed on the hottest part of the component (out of any direct airflow) and the equipment should be run until all temperatures have stabilised.

CIRCUIT REF.	DESCRIPTION	MAX. TEMP (°C)
-	Power transformer primary, secondary and core	130
T1, TX101, TX201	Module current transformer windings	127
XT1, XQ1	D, E & F Primary option transformers	90
XTR1	EY, FY, EV & FV Primary option transformers	90
TX1	xEW & xFW Primary option transformers	130
L1, L2, XT601	Choke winding	110
T2	Choke winding	117
L4	Choke winding	120
Various	All other choke & transformer windings	110
RLY1	Relay	100
C15	X capacitor	100
Various	All other X capacitors	105
C2, C3, C14	Electrolytic Capacitor	67
Various	All other 10mm dia Electrolytic Capacitor	80
Various	All other 12.5mm dia Electrolytic Capacitor	85

Modules

Modules	Note	Output Range	Current	Slots	Turns	Max. Current Limit	Settings for hazardous energy
B1L		1.8-3.8V	20A	1	1	25A	-
B1H		3.9-5.5V	20A	1	1	25A	-
B2		5.0-9V	25A	1	2	31.3A	>7.6V
B3		9.1-16.2V	12A	1	3	15A	>16V
B5		21.6-31V	6A	1	5	7.5A	>32V
C1		1.8-4.1V	35A	1	1	43.8A	>5.4V
C1Y	1	1.8-4.1V	40A	1	1	50A	-
C3		9.1-16.2V	18A	1	3	22.5A	>10.6V
C4		16.3-21.5V	14A	1	4	17.5A	>13.7V
C5		21.6-31V	10A	1	5	12.5A	>19.2V
D1L	2	1.8-3.8V	50A	1.5	1	62.5A	>3.8V
D1H	2	3.9-5.5V	50A	1.5	1	62.5A	>3.8V
D2	2	3.8-8V	45A	1.5	2	56.25A	>4.2V
D3	2	8-16.5V	24A	1.5	3	30A	>8V
D4	2	14-21.5V	18A	1.5	4	22.5A	>10.6V
D5	2	21-28V	15A	1.5	5	18.75A	>12.8V
E1		1.8-3.8V	60A	2	1	75A	>3.2V
E2	3	3.8-8V	60A	2	2	75A	>3.2V
E3L		8-13.9V	40A	2	3	50A	>4.8V
E3H		14-15V	36A	2	3	45A	>5.3V
E4		14-19.9V	30A	2	4	37.5A	>6.4V
E5L		20-24V	27A		5	33.8A	>7.1V
E5H		24-28V	25A	2	5	31.3A	>7.6V

Modules	Note	Output Range	Current	Slots	Turns	Max. Current Limit	Settings for hazardous energy
Standard Modules							
F1	4	1.8-3.8V	80A	2	1	100A	>2.4V
F2	3,4,5	3.8-8V	75A	2	2	100A	>2.4V
L1		4.2-5.5V	35A	1	1	43.8A	>5.4V
H1L/1L		1.8-3.8V	12A	1	1	15A	-
		1.8-3.8V	8A		1	12A	-
H1L/1H		1.8V-3.8V	12A	1	1	15A	-
		3.9-5.5V	8A		1	12A	-
H1H/1L		3.9-5.5V	12A	1	1	15A	-
		1.8-3.8V	8A		1	12A	-
H1H/1H		3.9-5.5V	12A	1	1	15A	-
		3.9-5.5V	8A		1	12A	-
H1L/2		1.8-3.8V	12A	1	1	15A	-
		5.6-9V	6A		2	9A	-
H1H/2		3.9-5.5V	12A	1	1	15A	-
		5.6-9V	6A		2	9A	-
H1L/3		1.8-3.8V	12A	1	1	15A	-
		9.1-16.2V	6A		3	9A	-
H1H/3		3.9-5.5V	12A	1	1	15A	-
		9.1-16.2V	6A		3	7.5A	-
H1L/4		1.8-3.8V	12A	1	1	15A	-
		16.3-25V	4.5A		4	6A	-
H1H/4		3.9-5.5V	12A	1	1	15A	-
		16.3-25V	4.5A		4	6A	-
H2/1L		5.6-9V	10A	1	2	15A	-
		1.8-3.8V	8A		1	12A	-
H2/1H		5.6-9V	10A	1	2	15A	-
		3.9-5.5V	8A		1	12A	-
H2/2		5.6-9V	10A	1	2	15A	-
		5.6-9V	6A		2	9A	-
H2/3		5.6-9V	10A	1	2	15A	-
		9.1-16.2V	6A		3	7.5A	-
H2/4		5.6-9V	10A	1	2	15A	-
		16.3-25V	4.5A		4	6A	-
H3/1L		9.1-16.2V	10A	1	3	15A	>16V
		1.8-3.8V	8A		1	12A	-
H3/1H		9.1-16.2V	10A	1	3	15A	>16V
		3.9-5.5V	8A		1	12A	-
H3/2		9.1-16.2V	10A	1	3	15A	>16V
		5.6-9V	6A		2	9A	-
H3-3		9.1-16.2V	10A	1	3	15A	>16V
		9.1-16.2V	6A		3	7.5A	-
H3/4		9.1-16.2V	10A	1	3	15A	>16V
		16.3-25V	4.5A		4	6A	-
H5/1L		16.2-28V	5A	1	5	7.5A	>32V
		1.8-3.8V	8A		1	12A	-
H5/1H		16.2-28V	5A	1	5	7.5A	>32V
		3.9-5.5V	8A		1	12A	-
H5/2		16.2-28V	5A	1	5	7.5A	>32V
		5.6-9V	6A		2	9A	-
XR1, X1	7,8	0-10V	90A	1	-	-	-
XR2, X2	7,8	0-20V	64.5A	1	-	-	-
XR4, X4	7,8	0-40V	32.4A	1	-	-	---
XR8, X8	7,8	0-80V	16.2A	1	-	-	-

Modules	Note	Output Range	Current	Slots	Turns	Max. Current Limit	Settings for hazardous energy
Standard Modules							
H5/3		16.2-28V	5A	1	5	7.5A	>32V
		9.1-16.2	6A		3	7.5A	
H5/4		16.2-28V	5A	1	5	7.5A	>32V
		16.3-25V	4.5A		4	6A	-
Seriesed Modules							
BB4		32.6-43V	10A	2	8	12.5A	>19.2V
CC3		18.2-32.4V	18A	2	6	22.5A	>10.6V
CC5		48.1-62V	10A	2	10	12.5A	>19.2V
DD4		28-43V	18A	3	8	22.5A	>10.6V
DD5		42-56V	15A	3	10	18.75A	>12.8V
EE2		7.6-16V	55A	4	4	75A	>3.2V
HH5/3		25.3-44.2V	5A	1	8	7.5A	>32V
HH5/4		32.5-53V	4.5A	1	9	6A	>40V
C5B4		43-48V	10A	2	9	12.5A	>19.2V
Paralleled Modules							
Z2(D1L+D1L)		1.8-3.8V	95A	3	1+1	125A	>1.9V
Z3(E1+E1)		1.8-3.8V	114A	4	1+1	150A	>1.6V
Z4(D1H+D1H)		3.9-5.5V	95A	3	1+1	125A	>1.9V
Z6(E2+D1H)		3.9-5.5V	104.5A	3.5	2+1	137.5A	>1.7V
Z7(D3+D3)		8-16.5V	45.6A	3	3+3	60A	>4V
Z18(L1+L1)		4.2-5.5V	66.5A	2	1+1	87.5A	>2.7V
Wide Range Modules							
W2	6	0.25-7.5V	30A	1	2	37.5A	>6.4V
W5	6	0.25-32V	8.5A	1	5	9.5A	>25.2V

Module Limitations - Notes:

- C1Y module is only permitted in slot 1.
- For PSUs with three D modules fitted or two D modules and an E module in slots 4/5 then D1L & D1H in slots 2/3 is limited to 42A and in slots 4/5 is limited to 47A. D2 in slots 2/3 is limited to 40A.
- E2 and F2 module fitted in slots 4/5 is limited to 55A.
- F1 and F2 modules are only permitted in slots 1 and 2.
- F2 module is limited to 40°C ambient for 80A load, and at 50°C must not exceed 75A load.
Important Note: The above module limitations apply to individual modules whether these are stand alone modules, or part of a series or parallel pair.
- W2 & W5 is followed by V or R indicating Voltage or Resistance programming, followed by 1, 2, 3 or 4, where:
 - Inhibit + Fixed or prog current limit + Fixed 0/V.
 - Inhibit + Fixed or prog current limit + Track 0/V.
 - Enable + Fixed or prog current limit + Fixed 0/V.
 - Enable + Fixed or prog current limit + Track 0/V.
- Actual voltage and current output of X and XR modules is dependent, and limited by, the ratings of the modules from which it is fed. The ratings given above for the X and XR modules are additional rating limitations imposed by the X or XR module itself.
- The maximum power output of psu's fitted with X modules is reduced from 450W by the following power:
 $Power = 0.55 \times (\text{Total X1 current}) + 0.7 \times (\text{Total X2} + \text{X4 current}) + 0.9 \times (\text{Total X8 current})$ Watts. Rating for XR module is identical to X module.
- Adjusting output voltage beyond the stated range may cause overvoltage protection (OVP) to operate, whereby all outputs will turn off. To reset OVP, turn back output voltage adjustment and remove the mains supply for 30 seconds and then switch back on.
- SELV and Outputs connected in Series
 Outputs are SELV except as described below
 - Non-earthed outputs that have secondaries with 2 or more turns are non-SELV as a single fault in the secondary may make them exceed the SELV limit between output and earth.
 - Non-earthed outputs that are connected in series are non-SELV unless all the seriesed outputs use 1 turn secondaries and there are no more than 3 outputs connected in series.

- Outputs connected in series are non-SELV if the total output voltage + 20% of the max, rated output voltage of the output with the highest rated voltage exceeds 60Vdc (the 20% addition allows for a single fault in any one individual channel)
- If any output or seriesed output is non-SELV then all the outputs in the PSU must be considered non-SELV
- Non-SELV outputs must be guarded or a deflector fitted during installation to avoid a service engineer making inadvertent contact with the output terminals, or dropping a tool onto them.
- The total voltage of a seriesed output must not exceed 160Vdc
- All outputs operational spacings to earth, and due consideration must be given to this in the end product design.

Custom Models

Model: Vega 450 AFT B/S 24D5S 21D5S (NS-CLE-010):

Input: 85-264Vac, 47-63Hz, Max. outputs: 24V, 12.5A; 21V, 7.143A

Model: Vega 450 AFT B/S 24E5HS (NS-CLE-011):

Input: 85-264Vac, 47-63Hz, Max. outputs: 24V, 14.59A, max. output power: 350W.

Model: NS-WKR/V4AFS 5/5H1H/1HFN 12/12H3/3F 5/5H1H/1HFN 25/25H5/4F:

Input: 90-264Vac, 47-63Hz, Max. outputs: 5.5V, 2.5A; 5.5V, 2.5A; 12.5V, 2.5A; 5.5V, 2.5A; 5.5V, 2.5A; 26V, 1.5A; 26V, 1.5A, max. output power: 195.5W

Model: Vega 450 ASS5FW 12.1C3S 3.33C1S 5.05B1HS 5.25/12.1H1H/3SR (K40089)

Input: 90-264Vac, 47-63Hz, Outputs: 12.1V, 9.5A; 3.3V, 9A;

5.05V, 20A; 12.1V, 2A; 5.25V, 4.7A, max. output power 294.53W.

Important safety instructions
Servicing

These products are not customer serviceable. Repairs may only be carried out by Lambda UK or their authorised agents.

Critical Applications

These products are not authorised for use as critical components in nuclear control systems, life support systems or equipment for use in hazardous environments without the express written approval of the Managing Director of Coutant Lambda Ltd.

Energy Hazards

Certain modules are capable of providing hazardous energy (240VA) according to output voltage setting. Final equipment manufacturers must provide protection to service personnel against inadvertent contact with these module output terminals. If set such that hazardous energy can occur then the module terminals or connections must not be user accessible.

Approval Limitations: Use in North America (AC units only)

When this product is used on 180VAC-250VAC mains with no neutral, connect the two live wires to L(live) and N (neutral) terminals on the input connector. In this instance double pole fusing is required.

High Voltage Warning

Dangerous voltages present within the power supply. Do not remove covers.

External Hot Surfaces

Section 6 of the Health and Safety at Work Act requires that manufacturers have an obligation to protect service engineers as well as users. In order to comply with this, a label must be fitted to these products which is clearly visible to service personnel accessing the overall equipment, and which legibly warns that surfaces of these products may be hot and must not be touched when the products are in operation. If the PSU has an IEC inlet fitted and the PSU face with the IEC inlet will be accessible to users then the temperature of this face must be determined in the end-use application.

Safety Earthing Screw

On products with an enclosure, special safety earthing screws are used which connect the cover to the chassis. They must not be removed.

Safety Class of Protection

These products are designed for the following parameters: Material Group IIIb, Pollution Degree 2, Overvoltage Category II, Class 1 (earthed), Indoor use as part of an overall equipment such that the product is accessible to service engineers only.

Safety approvals

UL60950-1 and CSA22.2No 60950-1 - UL Recognised. C-UL for Canada.
 IEC/EN60950-1 - CE mark.
 CE marking when applied to any Vega product, indicates compliance with the Low Voltage Directive (2006/95/EC) in that it complies with EN60950-1
 IEC/EN61010-1 and IEC/EN60601-1. CB Report and Certificate
 UL60601-1 and Recognised, C-UL for Canada.

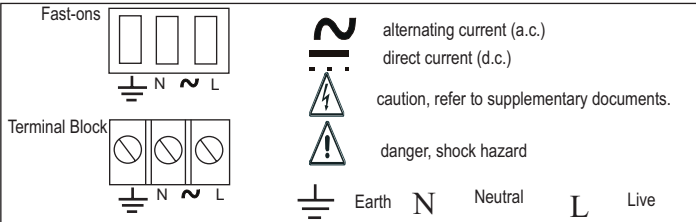
Input markings and symbols

Environmental parameters
Operation

Temperature 0 to 50°C (derating 2.5%/°C above 50°C to 65°C - Not covered by approvals).
 Humidity 5 to 95% RH non-condensing. Air Pressure 78kPa to 106kPa.
 Altitude -200m to 5000m. (3000m if IEC inlet or cooling options D or E fitted)
 (3000m for IEC/EN/UL60601-1)

Storage and Transportation

Temperature -40°C to +85°C. Humidity 5% to 95% RH non-condensing.
 Air Pressure 54kpa to 106kpa. Altitude -200m to 5000m.

Vibration and shock

10-200Hz @ 1.5G sinewave, 20G for 15 minutes in 3 axes random vibration / 3000 bumps, 10G (16mS) half sinewave.

Cooling

Provided that the fan air intake and air outlet slots are not impeded, these units may be mounted in any of 4 orientations: Horizontal, on either side, or vertical with airflow upwards. For correct

Level of insulation

Dielectric Strength testing is carried out as follows:

Primary mains circuit to earth - 2.25 - 2.35kVDC

Primary mains circuits to transformer core - 4.25 - 4.35kVDC*

Primary mains circuits to secondary -4.25 - 4.35kVDC*.

Outputs to each other and to earth are isolated to 200VDC.

*This test is not possible with modules fitted to the unit as damage to RFI capacitors will occur

EMC performance

Emissions: EN55022 Conducted RFI-Class A or B (depending on product - Consult Technical Sales). Radiated RFI - Class A,
 EN61000-3-2 / A14 - Pass - Class A and D. EN61000-3-3 / A1 - Pass
Immunity: EN61000-4-2 - Level 4 Criteria B EN61000-4-3 - Level 3 Criteria B
 EN61000-4-4 - Level 4 Criteria B EN61000-4-5 - Level 4 Criteria B, (Installation Class 4, Criteria B)
 EN61000-4-6 - Level 3 Criteria B EN61000-4-11 - Pass

General installation instructions

The Vega family of component power supplies is designed for use within other equipment or enclosures which restrict access to authorised competent personnel only. For safe installation and operation of this product, carefully follow the instructions listed below.

- i) The unit covers/chassis are designed to protect only skilled personnel from hazards and must not be made user accessible.
- ii) These products are Class 1 and must therefore be reliably earthed and professionally installed in accordance with the prevailing electrical wiring regulations and the safety standards covered herein.
- iii) These products are IPX0, and therefore chemicals/solvents, cleaning agents and other liquids must not be used.
- iv) If the earth terminal of the Vega PSU is connected to the main incoming earth conductor of the end equipment, the installer must cover the Vega earth symbol with a label bearing the earth symbol of IEC60417-5019
- v) For units where the fan grill is not fitted, the professional installer must apply appropriate measures to prevent users from the hazards of electric shock and moving parts and / or service persons from inadvertent contact with such hazards in accordance with the safety standards applicable to the end product.
- vi) The mains switch, where fitted is a single pole device and must not be used as the mains disconnect device. The IEC60320 mains appliance coupler is intended to be the mains disconnect device.

Special instructions for medical applications (IEC/EN/UL/CSA60601-1)

Applicable to products with L, R and T filter options only.

- i) These products are designed for continuous operation within an overall enclosure, and must be mounted such that access to the mains terminals is restricted. See Clause 16, IEC/EN/UL/CSA60601-1.
- ii) These products are NOT suitable for use in the presence of flammable anaesthetic mixtures with air or with oxygen or with nitrous oxide.
- iii) These products are classed as ordinary equipment according to IEC/EN/UL/CSA60601-1 and are NOT protected against the ingress of water.
- iv) Connect only apparatus complying with IEC/EN/UL/CSA60601-1, to the signal ports.
- v) Except for permanently installed equipment as defined in Clause 57.6 of IEC/EN/UL/CSA60601-1, the overall equipment in which these products are installed must have double pole fusing on the input mains supply or DC supply as appropriate. The products themselves have single pole fusing in the live line or positive DC line as appropriate.
- vi) Reference should be made to local regulations concerning the disposal of these products at the end of their useful life.

Special instructions for applications covered by IEC/EN/UL/CSA61010-1

Whilst all individual module single outputs are classed as SELV outputs in accordance with IEC/EN/UL/CSA60950-1 (<60Vdc or 42.4V peak) serried combinations of these modules may exceed these values and become hazardous output voltages. For IEC/EN/UL/CSA61010-1 the equivalent limits are 70Vdc, 33Vrms or 46.7V peak.

Under single fault conditions these limits are increased for IEC/EN/UL/CSA61010-1 to 140Vdc, 55Vrms or 78V peak. Provided these levels are not exceeded, the outputs are not considered hazardous for IEC/EN/UL/CSA61010-1

If the equipment is used in a manner not specified by the manufacturer, the protection provided by the equipment may be impaired.

Mechanical parameters

DO NOT USE MOUNTING SCREWS WHICH PENETRATE THE UNIT BY MORE THAN 4.5 MM.
Weight 2 Kg dependent upon configuration.

Connection details

Input Connections (see Table 1)

Input tabs - 6.3mm x 0.8mm, tin plated brass, rated 15A. Internal fuse (F1) 16A/250V or 10A/250V HBC fuse 6.3x32mm

Input Screw Terminals: 6-32 screws with 8.25mm spacing between screw head centres. Screw head diameter is 6.6mm.

Input IEC 60 320: Rated 10A/250Vac (15A/132Vac)

Mating input faston connectors				
Brand	Colour	Wire size (awg)	Part number	Current rating
Amp	Red	22 - 18	2-520407-2	15A
Amp	Blue	16 - 14	3-520408-2	15A

Output Connections

Output Connector Ratings: Single slot, single output modules (B, C, L modules): Two 6.35mm fast-ons per output each rated at 18A or M4 screw terminals rated at 35A. Single slot, twin output modules (H modules); One 6.35mm fast-on per output rated at 18A or M3 screw terminals rated at 15A. Dual slot, single output modules (D, E modules): Two 9.5mm fast-ons per output each rated at 32A, or M5 screw terminals rated at 90A

Maximum Torque Settings for Output Screw Terminals

M3 - 0.75Nm M4 - 1.5Nm M5 - 2.0Nm

Primary Options

Specified Option	Pin 5 Logic 0	Pin 6 Logic 1
Inhibit	Outputs OFF	Outputs OFF
Enable	Outputs ON	Outputs ON

Logic 0 = 0-0.8V. Logic 1 = 2.0 - 5.0V with respect to 0V (Pin 3)

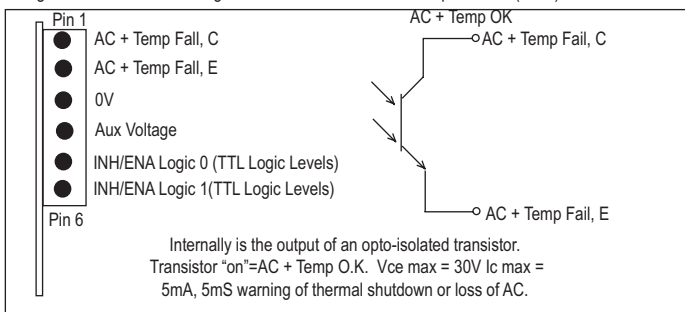

Input Filter Options		
Option	Max. Leakage at 264VAC, 63Hz	RFI EN55022 Class:
Standard	1.5mA max	B/A
M	650uA max	A
L	290uA max	A
R	175uA max	Above A
T	60uA max	Above A

Note:When primary options EW or FW are fitted the above values increase by 100uA.

Secondary Options

Remote Sense Option

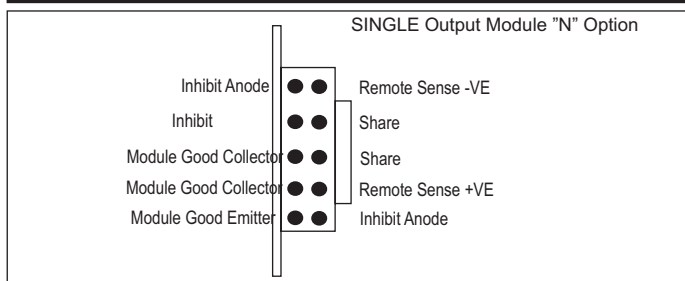

Inhibit

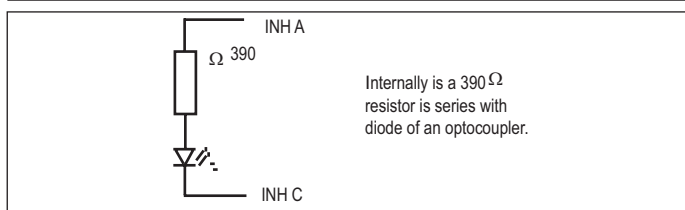

Module Good

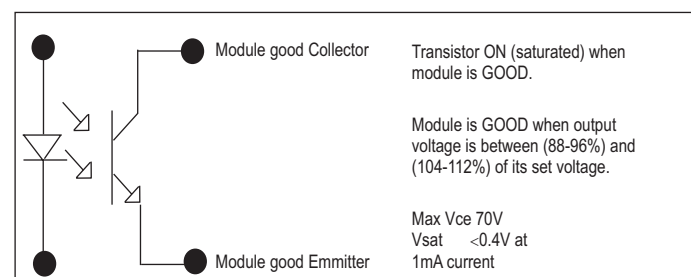

TWIN Output Module "N" Option

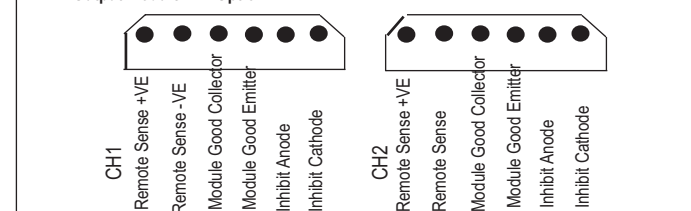

TWIN Output Module "R" Option

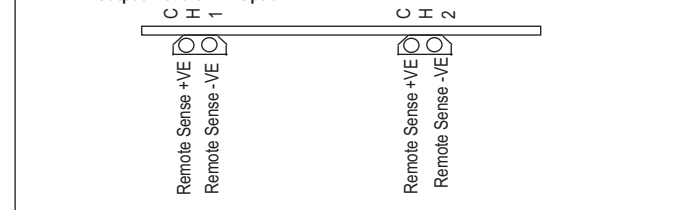

Single output module digital option

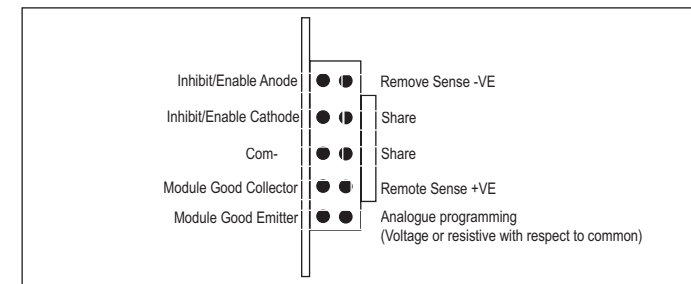

Single output wide range programmable module

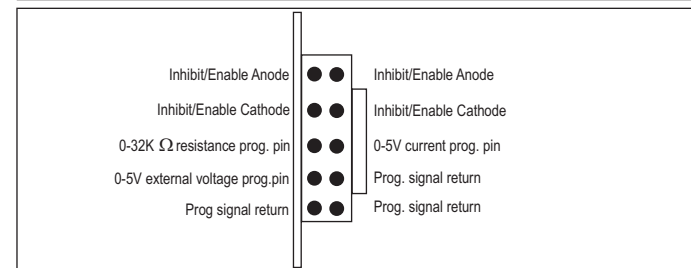

Customer fixings

Customer Air and Fixing detail

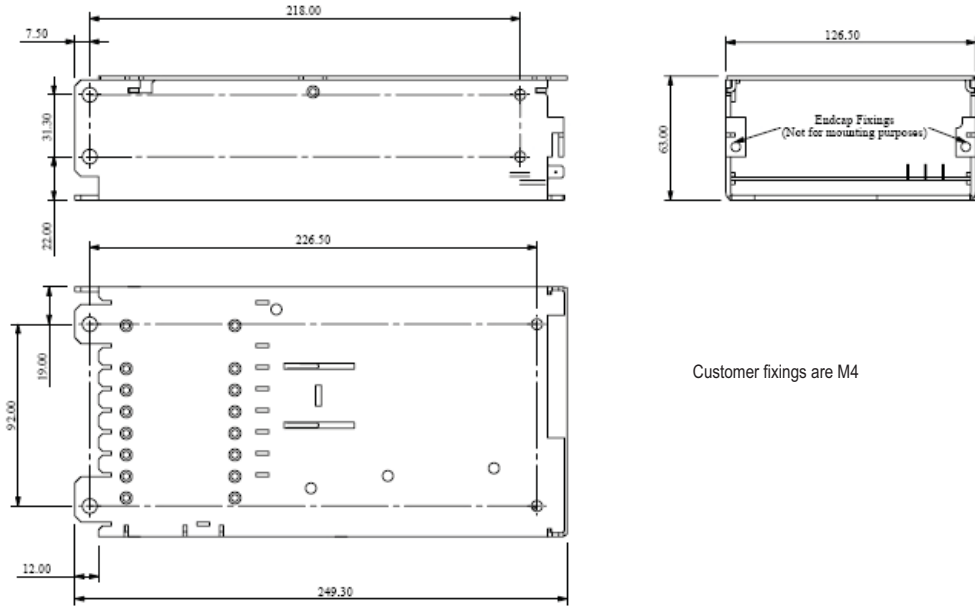

Customer fixings are M4

IEC 320 (Switched) Input

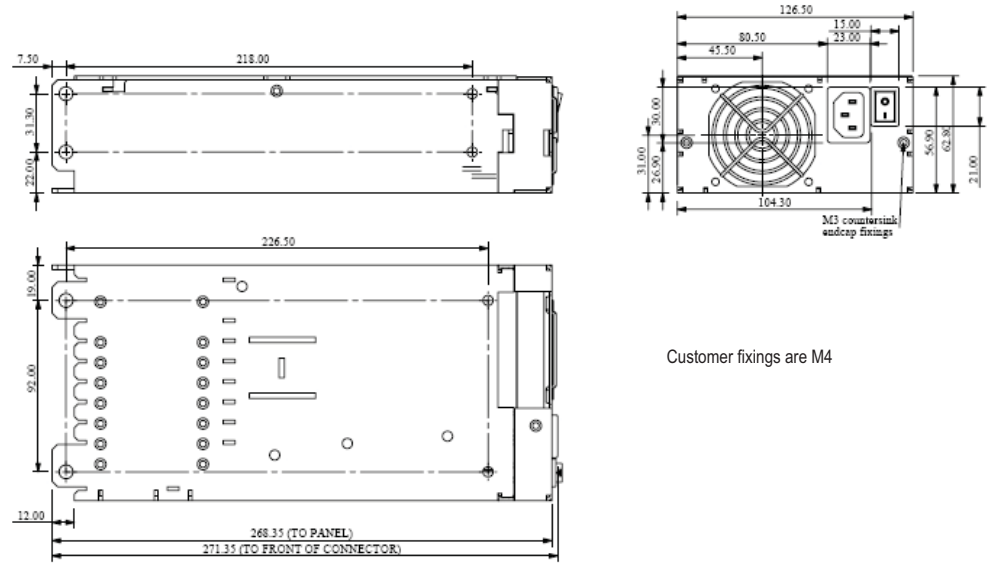

Customer fixings are M4

Quick Connect (Faston) Input

For fixing centres and general sizes see page for customer air option

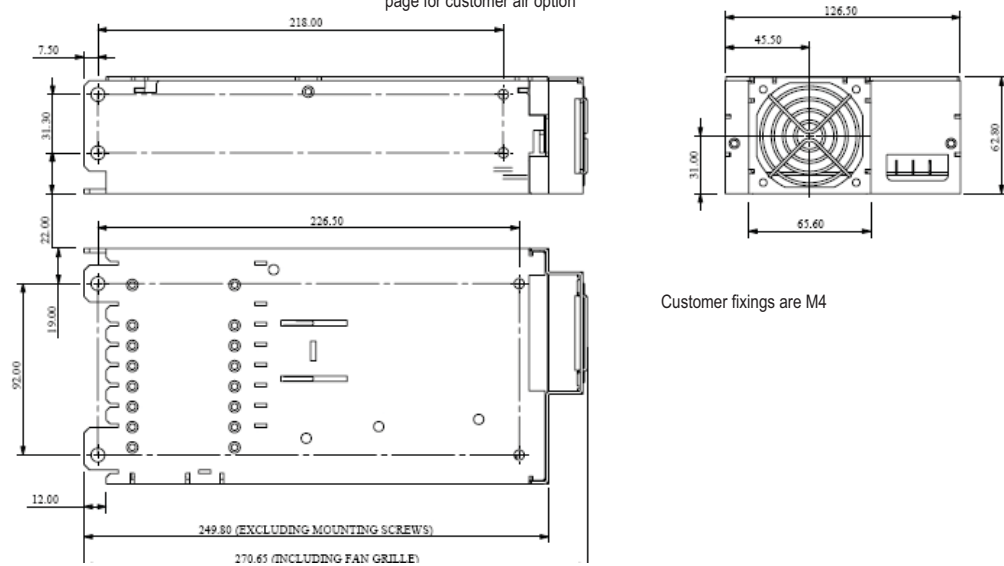

Customer fixings are M4

Right Angle Screw Terminal Input

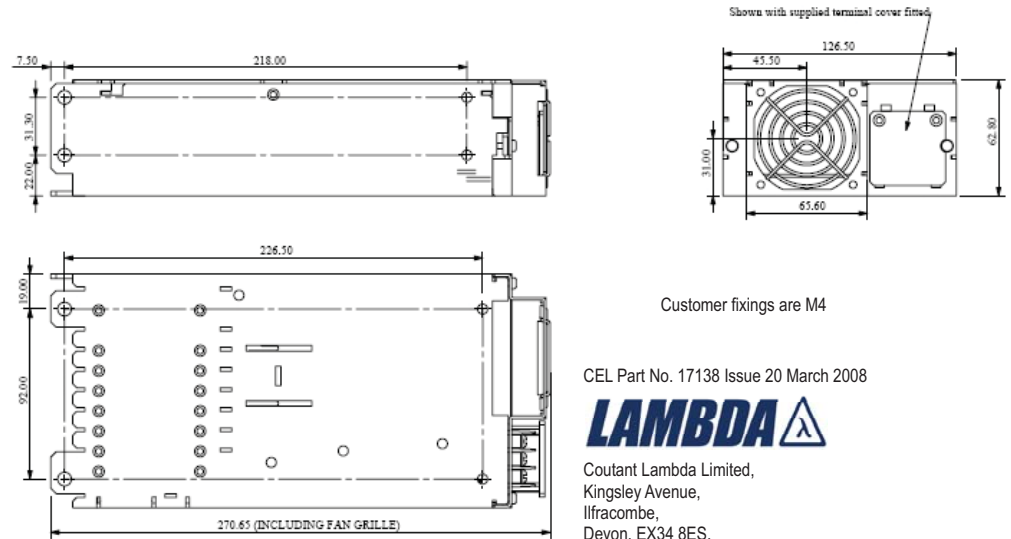

Customer fixings are M4

CEL Part No. 17138 Issue 20 March 2008



Coutant Lambda Limited,
Kingsley Avenue,
Ilfracombe,
Devon, EX34 8ES.
Telephone - Sales and Service (01271) 856666.
Head Office and Works (01271) 856600.
Facsimile (01271) 864894.
WEBSITE: www.lambda-gb.com