

Input Parameters

INPUT FREQUENCY	47-63Hz
INRUSH CURRENT	<40 AMPS

Output Parameters

Adjustment and Derating.

The Vega 900 series is designed to provide a max output power of 900W at nominal output voltages. The following procedure must be used to ensure the PSU is operated within its ratings

- Calculate user power for each module (volts x amps).
- Add all the individual module powers together. The total power must not exceed the value given.
- Calculate secondary transformer turns x amps for each module. See the outputs table for transformer secondary turns.
- Add all the module turns x amps together and this must not exceed the ampere turns.
- If necessary reduce the loading until the conditions are met, ie. power and ampere-turns maxima.

For applications where input voltage will always be equal to or greater than 150Vac ratings are as follows

NOMINAL INPUT VOLTAGE RANGE	165-240VAC
MAX INPUT VOLTAGE RANGE	150-264VAC
MAX INPUT CURRENT	9AAC

Cooling Option	Max Ambient	Dual Width Modules Fitted	Max Power	Max AT (total)	Max AT adjacent regions (note 1)	Max Current Rating
F,D (Standard or Ruggedised Fan Forward Airflow)	50	No	900	220	180	100%
		Yes	900	220	180	100%
		No	650	220	n/a	100%
Q (Quiet Fan Forward Airflow)	50	No	750	180	n/a	100%
		Yes	750	180	140	100%

* Ruggedised fan (Papst 622HH, not for use in PSU's fitted with IEC inlet).

Note 1: The PSU main transformer has three regions for module secondaries separated by two primary windings. Starting nearest slot 1, region A, primary winding, region B, primary winding, region C. The total ampere turns (AT) in any two adjacent regions is limited to that in the table above column, " Max AT in adjacent regions (note 1)". See mains transformer regions table below for modules allowed in each region. The table uses module widths with a twin output module being single width.

n/a=not applicable
Main transformer regions table:

Slot 1		Slot 5.5	
Region A	Region B	Region C	
Single	Dual	Dual	
Blank	Dual	Dual	
Single	Dual, Single	Single	
Single	Dual	Single	
Single	Dual	-	
-	Dual	-	
Single	Single, Single, Single	Single	
Single	Single, Single	Single	
Single	Single	-	
-	Single	-	
1.5	Dual	1.5	
Single	Dual	1.5	
-	Dual	1.5	
Single	1.5, Single	Single	
Single	1.5	-	
Single	1.5	Single	
1.5	1.5, Single	Single	
1.5	1.5	1.5	

Slot 1		Slot 5.5	
Region A	Region B	Region C	
Single	1.5	1.5	
-	1.5	1.5	
-	1.5	-	
-	Single, Single	Dual	
-	1.5, Single	Single	
-	Dual, Single	Single	
1.5	1.5	-	
Single	Single, Single	Dual	
1.5	1.5	Dual	
Combined Modules			
Single	Dual	Dual	
-	Dual	Dual	
1.5	Dual	1.5	
Single	Dual	1.5	
-	Dual	1.5	
Single	1.5, 1.5	Single	
Single	1.5, 1.5	-	
-	1.5, 1.5	-	
1.5	1.5, Dual	-	
1.5	1.5, Single	Single	
1.5	1.5	1.5	

For applications where input voltage may be less than 150V ac ratings are as follows.

NOMINAL INPUT VOLTAGE RANGE	94.5-240VAC
MAX INPUT VOLTAGE RANGE	85-264Vac
MAXIMUM INPUT CURRENT	12AAC

Cooling Option	Max Ambient	Dual Width Modules Fitted	Max Total Power	Max Total Ampere Turns (AT)	Special AT Limit**	Module Current Rating	
F (Standard Fan - Forward Airflow)	50	No	See Table Below	220	-	100%	
		Yes	See Table Below	220	180	100%	
D (Ruggedised fan - forward airflow)	50	No	650	220	-	100%	
		Yes	650	220	180	100%	
R,E (Standard or Ruggedised Fan - Reverse Airflow)	40	No	530	212	-	100%	
		Yes	550	212	158	90%	
	45	No	500	200	-	100%	
		Yes	500	212	158	90%	
	50	No	440	176	-	100%	
		Yes	420	212	158	90%	
Q (Quiet Fan - Forward Airflow)	50	No	550	180	-	100%	
		Yes	550	180	140	100%	
	50	No	650	145	-	100%	
		Yes	650	145	115	95%	
	P (Quiet Fan -Reverse Airflow)	40	No	440	176	-	100%
			Yes	500	203	152	85%
45		No	400	160	-	100%	
		Yes	420	203	152	85%	
50	No	350	140	-	100%		
	Yes	370	184	143	85%		

* Ruggedised fan (Papst 622HH, not for use in PSU's fitted with IEC inlet).

** For products with dual width modules the following rules apply:

One dual width module:

Total ampere turns for modules in slots 1 to 4 must be , the value shown in Special AT Limit column

Total ampere turns for modules in slots 2 to 5 must be , the value shown in Special AT Limit column

Total ampere turns for modules in slots 1 to 3 must be , the value shown in Special AT Limit column

Total ampere turns for modules in slots 2 to 5 must be , the value shown in Special AT Limit column

Power ratings for cooling option F:

Input Voltage (Vrms)	Output Power (W)
85	600
90	650
100	700
110-149.9	750
150-264	900

Linear interpolation may be used to determine the permitted output power for input voltages between 85 and 110V.

Customer Air Cooling (option C):

The following method must be used for determining the safe operation of PSUs when C option (Customer Air) is fitted, ie fan not fitted to PSU.

For PSUs cooled by customer supplied airflow the components listed in the following table must not exceed the temperatures given. Additionally ratings specified for units with an internal fan must still be complied with, eg mains input voltage range, maximum output power, ampere turns, module voltage / current ratings and maximum ambient temperature. To determine the component temperatures the heating tests must be conducted in accordance with the requirements of IEC/EN/CSA60950-1:2001 Clause 4.5. Consideration should also be give to the requirements of other safety standards.

Test requirements include: PSU to be fitted in its end-use equipment and operated under the most adverse conditions permitted in the end-use equipment handbook/specification and which will result in the highest temperatures in the PSU. To determine the most adverse conditions consideration should be given to the end use equipment maximum operating ambient, the PSU loading and input voltage, ventilation, end use equipment orientation, the position of doors & covers, etc. Temperatures should be monitored using type K fine wire thermocouples (secured with cyanoacrylate adhesive, or similar) placed on the hottest part of the component (out of any direct airflow) and the equipment should be run until all temperatures have stabilised.

CIRCUIT REF.	DESCRIPTION	MAX. TEMP (°C)
-	Power transformer primary, secondary and core	130
T1, TX101, TX201	Module current transformer windings	127
XT1, XQ1	D, E & F Primary option transformers	90
XTR1	EY, FY, EV & FV Primary option transformers	90
TX1	xEW & xFW Primary option transformers	130
L1, L2, XT601	Choke winding	110
T2	Choke winding	117
L4	Choke winding	120
Various	All other choke & transformer windings	110
RLY1	Relay	100
C15	X capacitor	100
Various	All other X capacitors	105
C2, C3, C14	Electrolytic Capacitor	67
Various	All other 10mm dia Electrolytic Capacitor	80
Various	All other 12.5mm dia Electrolytic Capacitor	85

Modules

Modules	Note	Output Range	Current	Slots	Turns	Max. Current Limit	Settings for hazardous energy
B1L		1.8-3.8V	20A	1	1	25A	-
B1H		3.9-5.5V	20A	1	1	25A	
B2		5.0-9V	25A	1	2	31.3A	>7.6V
B3		9.1-16.2V	12A	1	3	15A	>16V
B5		21.6-31V	6A	1	5	7.5A	>32V
C1		1.8-4.1V	35A	1	1	43.8A	>5.4V
C1Y	1	1.8-4.1V	40A	1	1	50A	-
C3		9.1-16.2V	18A	1	3	22.5A	>10.6V
C4		16.3-21.5V	14A	1	4	17.5A	>13.7V
C5		21.6-31V	10A	1	5	12.5A	>19.2V
D1L	2	1.8-3.8V	50A	1.5	1	62.5A	>3.8V
D1H	2	3.9-5.5V	50A	1.5	1	62.5A	>3.8V
D2	2	3.8-8V	45A	1.5	2	56.25A	>4.2V
D3	2	8-16.5V	24A	1.5	3	30A	>8V
D4	2	14-21.5V	18A	1.5	4	22.5A	>10.6V
D5	2	21-28V	15A	1.5	5	18.75A	>12.8V
E1		1.8-3.8V	60A	2	1	75A	>3.2V
E2	3	3.8-8V	60A	2	2	75A	>3.2V
E3L		8-13.9V	40A	2	3	50A	>4.8V
E3H		14-15V	36A	2	3	45A	>5.3V
E4		14-19.9V	30A	2	4	37.5A	>6.4V
E5L		20-24V	27A		5	33.8A	>7.1V
E5H		24-28V	25A	2	5	31.3A	>7.6V

Modules	Note	Output Range	Current	Slots	Turns	Max. Current Limit	Settings for hazardous energy
L1		4.2-5.5V	35A	1	1	43.8A	>5.4V
H1L/1L		1.8-3.8V	12A	1	1	15A	-
		1.8-3.8V	8A		1	12A	-
H1L/1H		1.8V-3.8V	12A	1	1	15A	-
		3.9-5.5V	8A		1	12A	-
H1H/1L		3.9-5.5V	12A	1	1	15A	-
		1.8-3.8V	8A		1	12A	-
H1H/1H		3.9-5.5V	12A	1	1	15A	-
		3.9-5.5V	8A		1	12A	-
H1L/2		1.8-3.8V	12A	1	1	15A	-
		5.6-9V	6A		2	9A	-
H1H/2		3.9-5.5V	12A	1	1	15A	-
		5.6-9V	6A		2	9A	-
H1L/3		1.8-3.8V	12A	1	1	15A	-
		9.1-16.2V	6A		3	9A	-
H1H/3		3.9-5.5V	12A	1	1	15A	-
		9.1-16.2V	6A		3	7.5A	-
H1L/4		1.8-3.8V	12A	1	1	15A	-
		16.3-25V	4.5A		4	6A	-
H1H/4		3.9-5.5V	12A	1	1	15A	-
		16.3-25V	4.5A		4	6A	-
H2/1L		5.6-9V	10A	1	2	15A	-
		1.8-3.8V	8A		1	12A	-
H2/1H		5.6-9V	10A	1	2	15A	-
		3.9-5.5V	8A		1	12A	-
H2/2		5.6-9V	10A	1	2	15A	-
		5.6-9V	6A		2	9A	-
H2/3		5.6-9V	10A	1	2	15A	-
		9.1-16.2	6A		3	7.5A	-
H2/4		5.6-9V	10A	1	2	15A	-
		16.3-25V	4.5A		4	6A	-
H3/1L		9.1-16.2V	10A	1	3	15A	>16V
		1.8-3.8V	8A		1	12A	-
H3/1H		9.1-16.2V	10A	1	3	15A	>16V
		3.9-5.5V	8A		1	12A	-
H3/2		9.1-16.2V	10A	1	3	15A	>16V
		5.6-9V	6A		2	9A	-
H3-3		9.1-16.2V	10A	1	3	15A	>16V
		9.1-16.2V	6A		3	7.5A	-
H3/4		9.1-16.2V	10A	1	3	15A	>16V
		16.3-25V	4.5A		4	6A	-
H5/1L		16.2-28V	5A	1	5	7.5A	>32V
		1.8-3.8V	8A		1	12A	-
H5/1H		16.2-28V	5A	1	5	7.5A	>32V
		3.9-5.5V	8A		1	12A	-
H5/2		16.2-28V	5A	1	5	7.5A	>32V
		5.6-9V	6A		2	9A	-
XR1,X1	6,7	0-10V	90A	1	-	-	-
XR2,X2	6,7	0-20V	64.5A	1	-	-	-
XR4,X4	6,7	0-40V	32.4A	1	-	-	---
XR8,X8	6,7	0-80V	16.2A	1	-	-	-

Modules	Note	Output Range	Current	Slots	Turns	Max. Current Limit	Settings for hazardous energy
H5/3		16.2-28V	5A	1	5	7.5A	>32V
		9.1-15.5	6A		3	7.5A	-
H5/4		16.2-28V	5A	1	5	7.5A	>32V
		16.3-24V	4.5A		4	6A	-
BB4		32.6-40V	10A	2	8	12.5A	>19.2V
CC3		18.2-30V	18A	2	6	22.5A	>10.6
CC5		48.1-60V	10A	2	10	12.5A	>19.2V
DD4		28-36V	18A	3	8	22.5A	>10.6V
DD5		42-56V	15A	3	10	18.75A	>12.8V
EE2		7.6-15V	55A	4	4	75A	>3.2V
EE4		28-38V	30A	4	8	37.5	>6.4
EE5L		40-48V	18A	4	10	33.8	>7.1
EE6H		48-56V	18A	4	10	31.3	>7.6
HH5/3		25.3-38V	5A	1	8	7.5A	>32V
HH5/4		32.5-46V	4.5A	1	9	6A	>40V
C5B4		43-48V	10A	2	9	12.5A	>19.2V
Z2(D1L+D1L)		1.8-3.4V	95A	3	1+1	125A	>1.9V
Z3(E1+E1)		1.8-3.4V	114A	4	1+1	150A	>1.6V
Z4(D1H+D1H)		3.9-5.1V	95A	3	1+1	125A	>1.9V
Z6(E2+D1H)		3.9-5.1V	104.5A	3.5	2+1	137.5A	>1.7V
Z7(D3+D3)		8-15V	45.6A	3	3+3	60A	>4V
Z18(L1+L1)		4.2-5.1V	66.5A	2	1+1	87.5A	>2.7V
Z19 (E5H+D5)		24-28V	36	3.5	5+5	40.05A	>5.9
W5	5	0.25-32V	8.5A	1	5	9.5A	18>25.2V

Module Limitations- Notes:

- C1Y module is only permitted in slot 1.
- For PSUs with three D modules fitted or two D modules and an E module in slots 4/5 then D1L & D1H in slots 2/3 is limited to 42A and in slots 4/5 is limited to 47A. D2 in slots 2/3 is limited to 40A.
- E2 module fitted in slots 4/5 is limited to 55A.
- SELV and Outputs connected in Series
Outputs are SELV except as described below
- Non-earthed outputs that have secondaries with 2 or more turns are non-SELV as a single fault in the secondary may make them exceed the SELV limit between output and earth.
- Non-earthed outputs that are connected in series are non-SELV unless all the seriesed outputs use 1 turn secondaries and there are no more than 3 outputs connected in series.
- Outputs connected in series are non-SELV if the total output voltage + 20% of the max, rated output voltage of the output with the highest rated voltage exceeds 60Vdc (the 20% addition allows for a single fault in any one individual channel)
- The total voltage of a seriesed output must not exceed 160Vdc
- If any output or seriesed output is non-SELV then all the outputs in the PSU must be considered non-SELV
Note
- Non-SELV outputs must be guarded or a deflector fitted during installation to avoid a service engineer making inadvertent contact with the output terminals, or dropping a tool onto them.
- All outputs operational spacings to earth, and due consideration must be given to this in the end product design.
- W5 is followed by V or R indicating voltage or resistance programming, followed by 1,2,3 or 4, where:
1 = Inhibit + fixed or prog current limit + fixed O/V
2 = Inhibit, fixed or prog current limit + track O/V
3 = Enable + fixed or prog current limit+ fixed O/V
- Actual voltage and current output of X and XR modules is dependent, and limited by, the ratings of the modules from which it is fed. The ratings given above for the X and XR modules are additional rating limitations imposed by the X or XR module itself.
- The maximum power output of psu's fitted with X modules is reduced from 900W by the following power:
Power=0.55 x (Total X1 current) + 0.7 x (Total X2 + X4 current) + 0.9 x (Total X8 current) Watts.
Rating for XR modules is identical to X modules.

- Adjusting output voltage beyond the stated range may cause overvoltage protection (OVP) to operate, whereby all outputs will turn off. To reset OVP, turn back output voltage adjustment and remove the mains supply for 30 seconds and then will switch back on.

Important safety instructions
Servicing

These products are not customer serviceable. Repairs may only be carried out by Lambda UK or their authorised agents.

Critical Applications

These products are not authorised for use as critical components in nuclear control systems, life support systems or equipment for use in hazardous environments without the express written approval of the Managing Director of Coutant Lambda Ltd.

Energy Hazards

Certain modules are capable of providing hazardous energy (240VA) according to output voltage setting. Final equipment manufacturers must provide protection to service personnel against inadvertent contact with these module output terminals. If set such that hazardous energy can occur then the module terminals or connections must not be user accessible.

Approval Limitations: Use in North America (AC units only)

When this product is used on 180VAC-250VAC mains with no neutral, connect the two live wires to L (live) and N (neutral) terminals on the input connector. In this instance double pole fusing is required.

High Voltage Warning

Dangerous voltages present within the power supply. Do not remove covers.

External Hot Surfaces

Section 6 of the Health and Safety at Work Act requires that manufacturers have an obligation to protect service engineers as well as users. In order to comply with this, a label must be fitted to these products which is clearly visible to service personnel accessing the overall equipment, and which legibly warns that surfaces of these products may be hot and must not be touched when the products are in operation. If the PSU's has an IEC inlet fitted and the PSU face with the IEC inlet will be accessible to users then the temperature of this face must be determined in the end-use application.

Safety Class of Protection

These products are designed for the following parameters : Material Group IIIb, Pollution Degree 2, Overvoltage Category II, Class 1 (earthed), Indoor use as part of an overall equipment such that the product is accessible to service engineers only.

Safety Earthing Screw

On products with an enclosure, special safety earthing screws are used which connect the cover to the chassis. They must not be removed.

Custom Model

Model: NS-THE/V9FSSF B/S 28E5HS (K90036)

Input: 90-264Vac, 47-63Hz

Maximum output: 28V, 25A, maximum output power: 700W

Safety approvals

UL60950-1 and CSA22.2 No.60950-1 - UL Recognised, C-UL for Canada.

IEC/EN60950-1 - CE mark.

CE marking when applied to any Vega product, indicates compliance with the Low Voltage Directive (2006/95/EC) in that it complies with EN60950-1.

IEC/EN61010-1 and IEC/EN60601-1. CB Report and Certificate

UL60601-1 and UL61010-1-UL Recognised, C-UL for Canada.

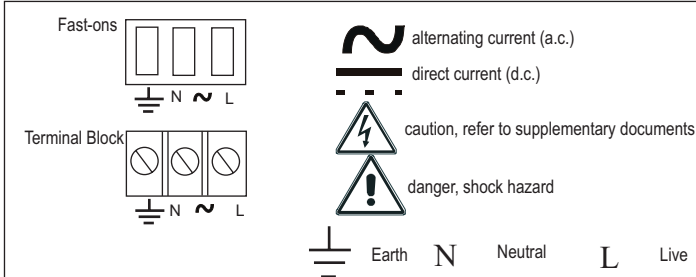
Input markings and symbols

Environmental parameters
Operation

Temperature 0 to 50°C (derating 2.5%/°C above 50°C to 65°C - Not covered by approvals). Humidity 5 to 95% RH non-condensing. Air Pressure 78kPa to 106kPa. Altitude -200m to 5000m (3000m if IEC inlet or cooling options D or E fitted) (3000m for IEC/EN/UL60601-1)

Storage and Transportation

Temperature -40°C to +85°C. Humidity 5% to 95% RH non-condensing. Air Pressure 54kPa to 106kPa. Altitude -200m to 5000m.

Vibration and shock

10-200Hz @ 1.5G sinewave, 20G for 15 minutes in 3 axes random vibration / 3000 bumps, 10G (16mS) half sinewave.

Cooling

Provided that the fan air intake and air outlet slots are not impeded, these units may be mounted in any of 4 orientations: Horizontal, on either side, or vertical with airflow upwards. For correct

Level of insulation

Dielectric Strength testing is carried out as follows

Primary mains circuit to earth - 2.25 - 2.35kVDC

Primary mains circuits to transformer core - 4.25 - 4.35kVDC*

Primary mains circuits to secondary -4.25 - 4.35kVDC*

Outputs to each other and to earth are isolated to 200VDC.

*This test is not possible with modules fitted to the unit as damage to RFI capacitors will occur

EMC performance

Emissions : EN55022 Conducted RFI-Class A or B (depending on product - Consult Technical Sales). Radiated RFI - Class A

EN61000-3-2 / A14 - Pass - Class A and D. EN61000-3-3 / A1 - Pass

Immunity: EN61000-4-2 - Level 4 Criteria B EN61000-4-3 - Level 3 Criteria B

EN61000-4-4 - Level 4 Criteria B EN61000-4-5 - Level 4 Criteria B, (Installation Class 4, Criteria B)

EN61000-4-6 - Level 3 Criteria B EN61000-4-11 - Pass

General installation instructions

The Vega family of component power supplies is designed for use within other equipment or enclosures which restrict access to authorised competent personnel only. For safe installation and operation of this product, carefully follow the instructions listed below.

i) The unit covers/chassis are designed to protect only skilled personnel from hazards and must not be made user accessible.

ii) These products are Class 1 and must therefore be reliably earthed and professionally installed in accordance with the prevailing electrical wiring regulations and the safety standards covered herein.

iii) These products are IPX0, and therefore chemicals/solvents, cleaning agents and other liquids must not be used.

iv) If the earth terminal of the Vega PSU is connected to the main incoming earth conductor of the end equipment, the installer must cover the Vega earth symbol with a label bearing the earth symbol of IEC60417-5019.

v) The mains switch, where fitted, is a single pole device and must not be used as the mains disconnect device. The IEC60320 mains appliance coupler is intended to be the mains disconnect device.

Special instructions for medical applications (IEC/EN/UL/CSA60601-1)
Applicable to products with L, R and T filter options only.

i) These products are designed for continuous operation within an overall enclosure, and must be mounted such that access to the mains terminals is restricted. See Clause 16, IEC/EN/UL/CSA60601-1,

ii) These products are NOT suitable for use in the presence of flammable anaesthetic mixtures with air or with oxygen or with nitrous oxide.

iii) These products are classed as ordinary equipment according to IEC/EN/UL/CSA60601-1 and are NOT protected against the ingress of water.

iv) Connect only apparatus complying with IEC/EN/UL/CSA60601-1, to the signal ports.

v) Except for permanently installed equipment as defined in Clause 57.6 of IEC/EN/UL/CSA60601-1, the overall equipment in which these products are installed must have double pole fusing on the input mains supply or DC supply as appropriate. The products themselves have single pole fusing in the live line or positive DC line as appropriate.

vi) Reference should be made to local regulations concerning the disposal of these products at the end of their useful life.

Special instructions for applications covered by IEC/EN/UL/CSA61010-1.

Whilst all individual module single outputs are classed as SELV outputs in accordance with IEC/EN/UL/CSAEN60950-1 (<60Vdc or 42.4V peak) series combinations of these modules may exceed these values and become hazardous output voltages. For IEC/EN/UL/CSA61010-1 the equivalent limits are 70Vdc, 33Vrms or 46.7V peak.

Under single fault conditions these limits are increased for IEC/EN/UL/CSA61010-1 and UL3101-1 to 140Vdc, 55Vrms or 78V peak. Provided these levels are not exceeded, the outputs are not considered hazardous for IEC/EN/UL/CSA61010-1

If the equipment is used in a manner not specified by the manufacturer, the protection provided by the equipment may be impaired.

Mechanical parameters

DO NOT USE MOUNTING SCREWS WHICH PENETRATE THE UNIT BY MORE THAN 4.5 MM. Weight 2 Kg dependent upon configuration.

Connection details

Mating input faston connectors				
Brand	Colour	Wire size (awg)	Part number	Current rating
Amp	Red	22 - 18	2-520407-2	15A
Amp	Blue	16 - 14	3-520408-2	15A

Input Connections

Input tabs - 6.3mm x 0.8mm, tin plated brass, rated 15A. Internal fuse (F1) 16A/250V fast acting HBC fuse 6.3x32mm

Input Screw Terminals: 6-32 screws with 8.25mm spacing between screw head centres. Screw head diameter is 6.6mm.

Input IEC 320: Rated 10A/250Vac (15A/132Vac)

Output Connections

Output Connector Ratings: Single slot, single output modules (B, C, L modules): Two 6.35mm fast-ons per output each rated at 18A or M4 screw terminals rated at 35A. Single slot, twin output modules (H modules): One 6.35mm fast-on per output rated at 18A or M3 screw terminals rated at 15A. Dual slot, single output modules (D, E modules): Two 9.5mm fast-ons per output each rated at 32A, or M5 screw terminals rated at 90A

Maximum Torque Settings for Output Screw Terminals

M3 - 0.75Nm M4 - 1.5Nm M5 - 2.0Nm

Primary Options

Specified Option	Pin 5 Logic 0	Pin 6 Logic 1
Inhibit	Outputs OFF	Outputs OFF
Enable	Outputs ON	Outputs ON

Logic 0 = 0-0.8V.

Logic 1 = 2.0 - 5.0V

with respect to 0V (Pin 3)

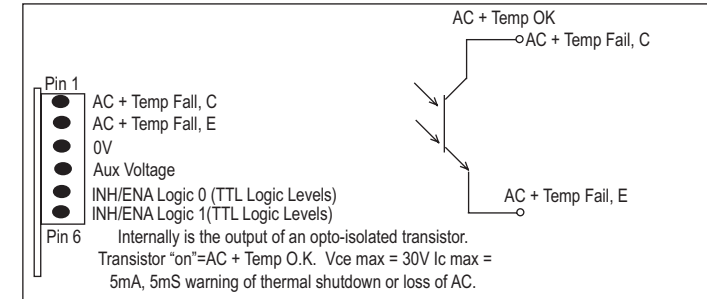

Input Filter Options		
Option	Max. Leakage at 264VAC,63Hz	RFI EN55022 Class
Standard	1.5mA max	B/A
M	650uA max	A
L	290uA max	A
R	175uA max	Above A
T	60uA max	Above A

Note: When primary options EW or FW are fitted the above values increase 100uA

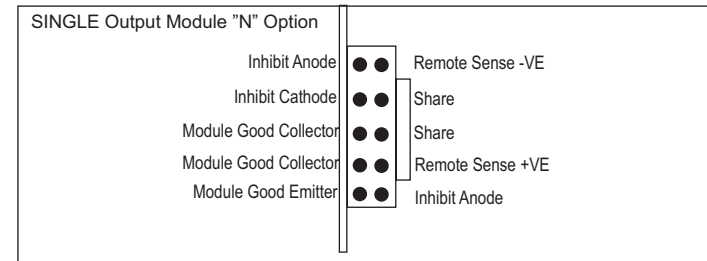
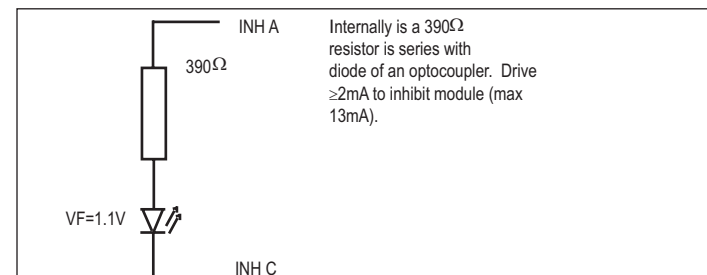
Secondary Options
Remote Sense Option

Inhibit

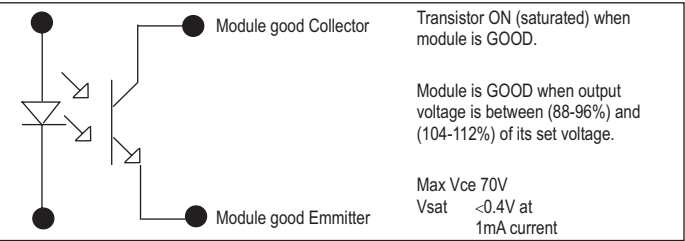
Module Good

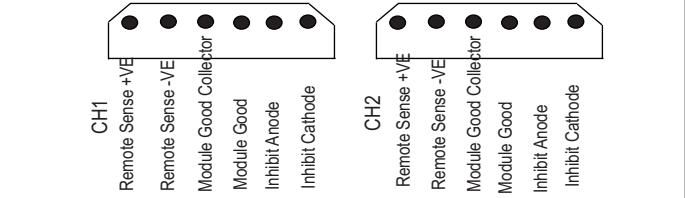

TWIN Output Module "N" Option



TWIN Output Module "R" Option

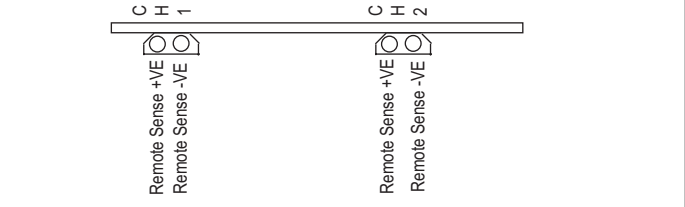

Single output module digital option

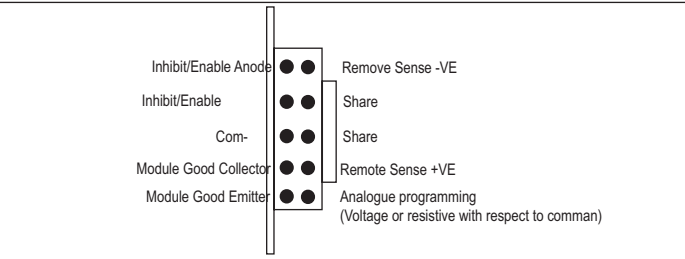

Single output wide range programmable module

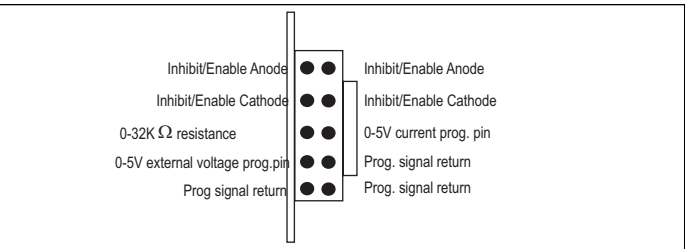

Customer fixings

Customer Air and Fixing detail

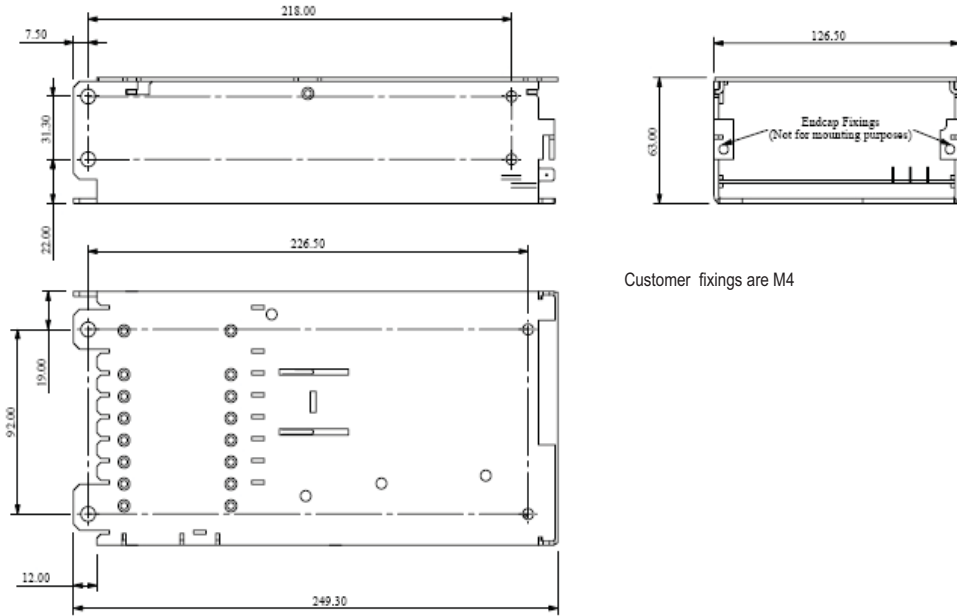

Customer fixings are M4

IEC 320 (Switched) Input

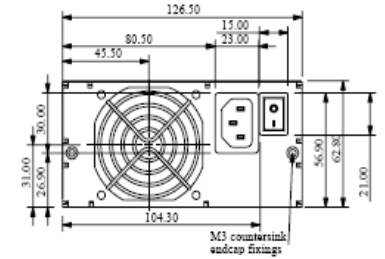
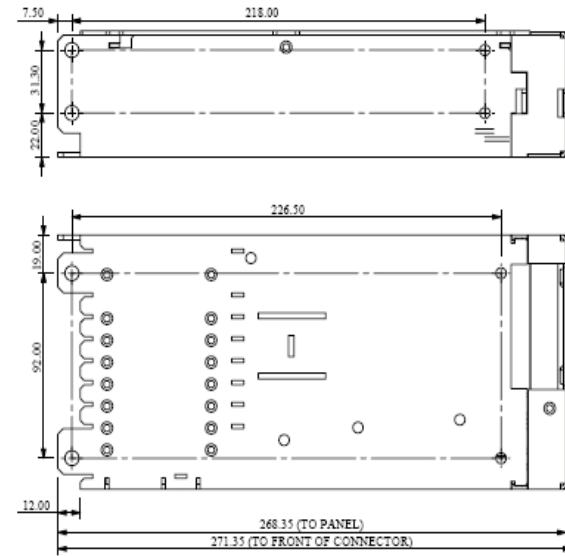

Customer fixings are M4

Quick Connect (Faston) Input

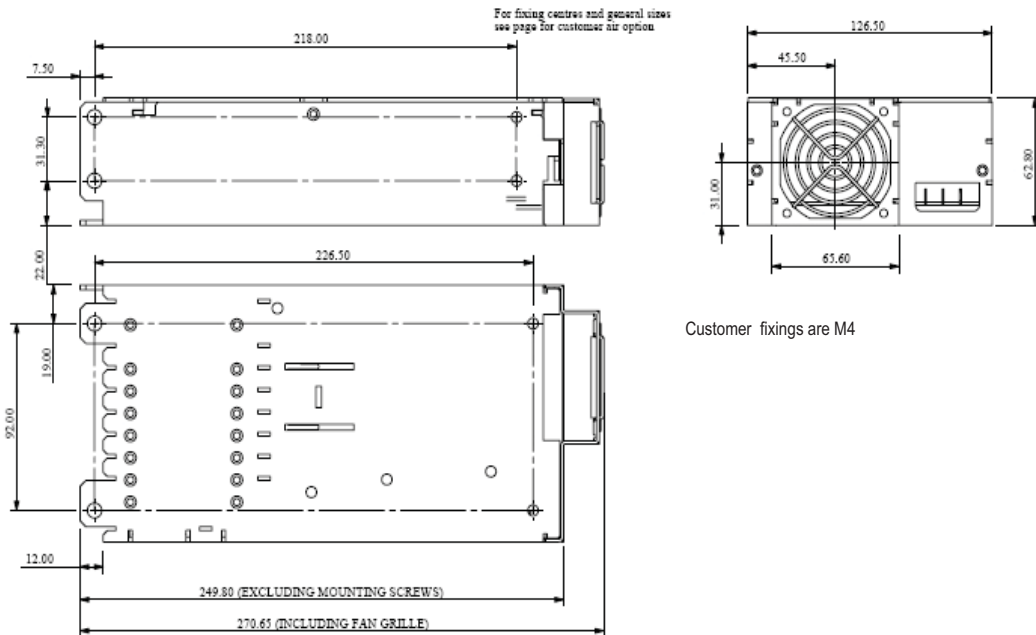

Customer fixings are M4

Right Angle Screw Terminal Input

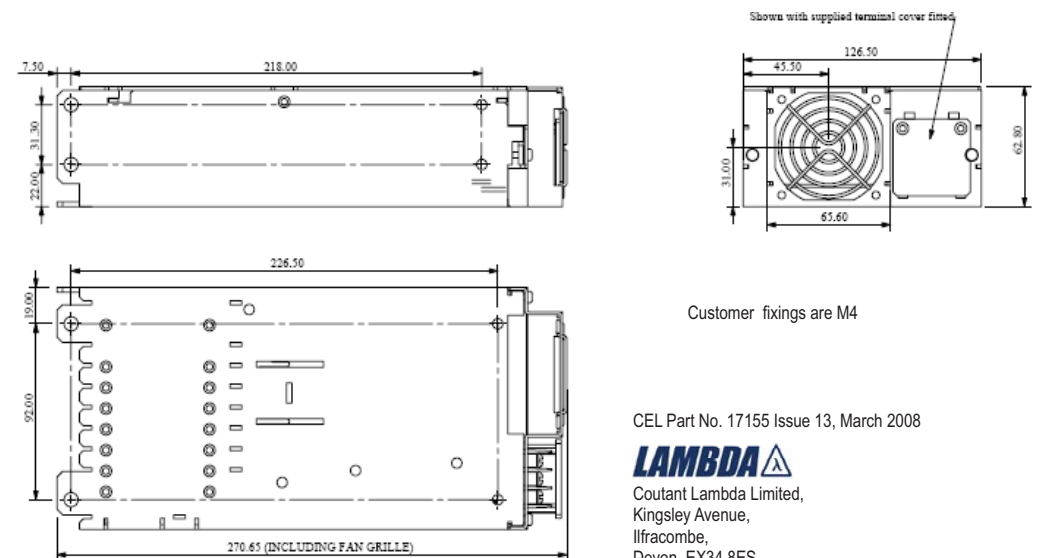

Customer fixings are M4

CEL Part No. 17155 Issue 13, March 2008



Coutant Lambda Limited,
Kingsley Avenue,
Ilfracombe,
Devon, EX34 8ES.
Telephone - Sales and Service (01271) 856666.
Head Office and Works (01271) 856600.
Facsimile (01271) 864894.
WEBSITE: www.lambda-gb.com