

Input Parameters

NOMINAL INPUT VOLTAGE RANGE	94.5 - 240VAC
MAX. INPUT VOLTAGE RANGE	85-264VAC
INPUT FREQUENCY	47-63Hz
MAXIMUM INPUT CURRENT	12 AAC
INRUSH CURRENT	<40 AMPS
MAXIMUM AMBIENT	50°C

Output Parameters

Adjustment and Derating.

The following procedure must be used to ensure the PSU is used within its ratings:

- ◆ Calculate user power for each module (volts x amps).
- ◆ Add all the individual module powers together. The total power must not exceed the value given.
- ◆ Calculate secondary transformer turns x amps for each module. See the outputs table for transformer secondary turns.
- ◆ Add all the module turns x amps together and this must not exceed 220.
- ◆ For products with dual width modules the following rules apply:
One Dual Width module:
Total Ampere turns for modules in slots 1 to 4 must not exceed 180.
Total Ampere turns for modules in slots 2 to 5 must not exceed 180.
Two Dual Width modules:
Total Ampere turns for modules in slots 1 to 3 must not exceed 180.
Total Ampere turns for modules in slots 2 to 5 must not exceed 180
- ◆ If necessary reduce the loading until the conditions are met, ie. power and ampere-turns maxima.

Input Voltage (Vrms)	Output Power (W)
85	600
90	650
100	700
110 - 149.9	750
150 - 264	900

Linear interpolation may be used to determine the permitted output power for input voltages between 85 and 110V.

Modules

Mod-ules	Note	Output Range	Current	Slots	Turns	Max. Current Limit	Settings for hazardous energy
Standard Modules							
B2		5.0-8V	25A	1	2	31.3A	>7.6V
C1		1.8-3.4V	35A	1	1	43.8A	>5.4V
C3		9.1-15V	18A	1	3	22.5A	>10.6V
C4		16.3-18V	14A	1	4	17.5A	>13.7V
C5		21.6-30V	10A	1	5	12.5A	>19.2V
D1L	1	1.8-3.4V	50A	1.5	1	62.5A	>3.8V
D1H	1	3.9-5.1V	50A	1.5	1	62.5A	>3.8V
D2	1	3.8-7.5V	45A	1.5	2	56.25A	>4.2V
D3	1	8-15V	24A	1.5	3	30A	>8V
D4	1	14-18V	18A	1.5	4	22.5A	>10.6V
D5	1	21-28V	15A	1.5	5	18.75A	>12.8V
E1		1.8-3.4V	60A	2	1	75A	>3.2V
E2	2	3.8-7.5V	60A	2	2	75A	>3.2V
E3L		8-12.5V	40A	2	3	50A	>4.8V
E4		14-19V	30A	2	4	37.5A	>6.4V
E5H		24-28V	25A	2	5	31.3A	>7.6V

Modules	Note	Output Range	Current	Slots	Turns	Max. Current Limit	Settings for hazardous energy
Standard Modules							
L1		4.2 - 5.1V	35A	1	1	43.8A	>5.4V
H1H/1L		3.9 - 5.1V	12A	1	1	15A	-
		1.8 - 3.4V	8A		1	12A	-
H1H/3		3.9 - 5.1V	12A	1	1	15A	-
		9.1 - 15.5V	6A		3	7.5A	-
H3/1H		9.1 - 15.5V	10A	1	3	15A	>16V
		3.9 - 5.1V	8A		1	12A	-
H3/3		9.1 - 15.5V	10A	1	3	15A	>16V
		9.1 - 15.5V	6A		3	7.5A	-
H5/1H		16.2 - 28V	5A	1	5	7.5A	>32V
		3.9 - 5.1V	8A		1	12A	-
H5/3		16.2 - 28V	5A	1	5	7.5A	>32V
		9.1 - 15.5V	6A		3	7.5A	-
H5/4		16.2 - 28V	5A	1	5	7.5A	>32V
		16.3 - 24V	4.5A		4	6A	-
Seriesed Modules							
BB4		32.6 - 40V	10A	2	8	12.5A	>19.2V
DD5	3	42 - 56V	15A	3	10	18.75A	>12.8V
HH5/4	3	32.5 - 52V	4.5A	1	9	6A	>40V
C5B4	3	43 - 48V	10A	2	9	12.5A	>19.2V

Module Limitations - Notes:

1. For PSUs with three D modules fitted or two D modules and an E module in slots 4/5 then D1L & D1H in slots 2/3 is limited to 42A and in slots 4/5 is limited to 47A. D2 in slots 2/3 is limited to 40A.
2. E2 module fitted in slots 4/5 is limited to 55A.
3. Modules DD5, C5B4 and HH5/4 must be considered non-SELV for IEC/EN/UL/CSA60950-1, since under a fault condition they may reach voltages in excess of SELV levels. As a result, all outputs on products containing any of these modules must be considered non-SELV.
4. Adjusting output voltage beyond the stated range may cause overvoltage protection (OVP) to operate, whereby all outputs will turn off. To reset OVP, turn back output voltage adjustment and remove the mains supply for 30 seconds and then switch back on.
5. SELV and Outputs connected in Series
Outputs are SELV except as described below
 - Non-earthed outputs that have secondaries with 2 or more turns are non-SELV as a single fault in the secondary may make them exceed the SELV limit between output and earth.
 - Non-earthed outputs that are connected in series are non-SELV unless all the seriesed outputs use 1 turn secondaries and there are no more than 3 outputs connected in series.
 - Outputs connected in series are non-SELV if the total output voltage + 20% of the max, rated output voltage of the output with the highest rated voltage exceeds 60Vdc (the 20% addition allows for a single fault in any one individual channel)
 - The total voltage of a seriesed output must not exceed 160Vdc
 - If any output or seriesed output is non-SELV then all the outputs in the PSU must be considered non-SELV
 - Non-SELV outputs must be guarded or a deflector fitted during installation to avoid a service engineer making inadvertent contact with the output terminals, or dropping a tool onto them.
 - All outputs operational spacings to earth, and due consideration must be given to this in the end product design.

Important safety instructions

Servicing

These products are not customer serviceable. Repairs may only be carried out by Lambda UK or their authorised agents.

Critical Applications

These products are not authorised for use as critical components in nuclear control systems, life support systems or equipment for use in hazardous environments without the express written approval of the Managing Director of Coutant Lambda Ltd.

Energy Hazards

Certain modules are capable of providing hazardous energy (240VA) according to output voltage setting. Final equipment manufacturers must provide protection to service personnel against inadvertent contact with these module output terminals. If set such that hazardous energy can occur then the module terminals or connections must not be user accessible.

Approval Limitations: Use in North America (AC units only)

When this product is used on 180VAC-250VAC mains with no neutral, connect the two live wires to L (live) and N (neutral) terminals on the input connector. In this instance double pole fusing is required.

High Voltage Warning

Dangerous voltages present within the power supply. Do not remove covers.

External Hot Surfaces

Section 6 of the Health and Safety at Work Act requires that manufacturers have an obligation to protect service engineers as well as users. In order to comply with this, a label must be fitted to these products which is clearly visible to service personnel accessing the overall equipment, and which legibly warns that surfaces of these products may be hot and must not be touched when the products are in operation.

Safety Earthing Screw

On products with an enclosure, special safety earthing screws are used which connect the cover to the chassis. They must not be removed.

Safety Class of Protection

These products are designed for the following parameters: Material Group IIIB, Pollution Degree 2, Overvoltage Category II, Class 1 (earthed), Indoor use as part of an overall equipment such that the product is accessible to service engineers only.

Safety approvals

UL60950-1 and CSA22.2 No.60950-1 - UL Recognised. C-UL for Canada.
IEC/EN60950-1 - CE mark.
CE marking when applied to any Vega - Lite product, indicates compliance with the Low Voltage Directive (2006/95/EC) in that it complies with EN60950-1.
IEC/EN61010-1 and IEC/EN60601-1. CB Report and Certificate.
UL60601-1 and UL61010-1-UL Recognised, C-UL for Canada.

Input markings and symbols

Terminal Block

means alternating current (a.c.).
 means direct current (d.c.).
 danger, shock hazard
 caution, refer to supplementary documents.

L - LIVE N - NEUTRAL E - EARTH

Environmental parameters

Operation
Temperature 0 to 50°C (derating 2.5%/°C above 50°C to 65°C - Not covered by approvals).
Humidity 5 to 95% RH non-condensing. Air Pressure 78kPa to 106kPa.
Altitude -200m to 5000m (3000m for IEC/EN/UL60601-1)
Storage and Transportation
Temperature -40°C to +85°C. Humidity 5% to 95% RH non-condensing.
Air Pressure 54kpa to 106kpa. Altitude -200m to 5000m.

Vibration and shock
10-200Hz @ 1.5G sinewave, 20G for 15 minutes in 3 axes random vibration / 3000 bumps, 10G (16mS) half sinewave.
Cooling
Provided that the fan air intake and air outlet slots are not impeded, these units may be mounted in any of 4 orientations: Horizontal, on either side, or vertical with airflow upwards. For correct airflow, allow 50mm clearance around the side and ends of the product.

Level of insulation

Dielectric Strength testing is carried out as follows: Primary mains circuit to earth - 2.25 - 2.35kVDC; **Primary mains circuits to transformer core - 4.25 - 4.35kVDC; **Primary mains circuits to secondary -4.25 - 4.35kVDC. Outputs to each other and to earth are isolated to 200VDC. (**This test is not possible with modules fitted to the unit as damage to RFI capacitors will occur).

EMC performance

Emissions : EN55022 Conducted RFI-Class A or B (depending on product - Consult Technical Sales). Radiated RFI - Class A,
EN61000-3-2 / A14 - Pass - Class A and D. EN61000-3-3 / A1 - Pass
Immunity: EN61000-4-2 - Level 4 Criteria B EN61000-4-3 - Level 3 Criteria B
EN61000-4-4 - Level 4 Criteria B EN61000-4-5 - Level 4 Criteria B, (Installation Class 4, Criteria B)
EN61000-4-6 - Level 3 Criteria B EN61000-4-11 - Pass

General installation instructions

The Vega - Lite family of component power supplies is designed for use within other equipment or enclosures which restrict access to authorised competent personnel only. For safe installation and operation of this product, carefully follow the instructions listed below.

- The unit covers/chassis are designed to protect only skilled personnel from hazards and must not be made user accessible.
- These products are Class 1 and must therefore be reliably earthed and professionally installed in accordance with the prevailing electrical wiring regulations and the safety standards covered herein.
- These products are IPX0, and therefore chemicals/solvents, cleaning agents and other liquids must not be used.
- If the earth terminal of the Vega - Lite PSU is connected to the main incoming earth conductor of the end equipment, the installer must cover the Vega - Lite earth symbol with a label bearing the earth symbol of IEC60417-5019.

Special instructions for medical applications (IEC/EN/UL60601-1)

Applicable to products with L, R and T filter options only.

- These products are designed for continuous operation within an overall enclosure, and must be mounted such that access to the mains terminals is restricted. See Clause 16, IEC/EN/UL60601-1.
- These products are NOT suitable for use in the presence of flammable anaesthetic mixtures with air or with oxygen or with nitrous oxide.
- These products are classed as ordinary equipment according to IEC/EN/UL60601-1 and are NOT protected against the ingress of water.
- Only only apparatus complying with IEC/EN/UL60601-1 to the signal ports.
- Except for permanently installed equipment as defined in Clause 57.6 of IEC/EN/UL60601-1 the overall equipment in which these products are installed must have double pole fusing on the input mains supply or DC supply as appropriate. The products themselves have single pole fusing in the live line or positive DC line as appropriate.
- Reference should be made to local regulations concerning the disposal of these products at the end of their useful life.

Special instructions for applications covered by IEC/EN/UL61010-1.

Whilst all individual module single outputs are classed as SELV outputs in accordance with IEC/EN/UL/CSA, EN60950-1 (<60Vdc or 42.4V peak) series combinations of these modules may exceed these values and become hazardous output voltages. For IEC/EN/UL61010-1 the equivalent limits are 70Vdc, 33Vrms or 46.7V peak.
Under single fault conditions these limits are increased for IEC/EN/UL61010-1 to 140Vdc, 55Vrms or 78V peak. Provided these levels are not exceeded, the outputs are not considered hazardous for IEC/EN/UL61010-1.
If the equipment is used in a manner not specified by the manufacturer, the protection provided by the equipment may be impaired.

Mechanical parameters

DO NOT USE MOUNTING SCREWS WHICH PENETRATE THE UNIT BY MORE THAN 4.5 MM.
Weight 2 Kg dependent upon configuration.

Connection details

Input Connections

Internal fuse (F1) 16A/250V fast acting HBC fuse 6.3x32mm.
Input Screw Terminals: 6-32 screws with 8.25mm spacing between screw head centres. Screw head diameter is 6.6mm.

Output Connections

Output Connector Ratings: Single slot, single output modules (B, C, L modules): M4 screw terminals rated at 35A. Single slot, twin output modules (H modules); M3 screw terminals rated at 15A. Dual slot, single output modules (D, E modules): M5 screw terminals rated at 90A

Maximum Torque Settings for Output Screw Terminals

M3 - 0.75Nm M4 - 1.5Nm M5 - 2.0Nm

Primary Options

Specified Option	Pin 5 Logic 0	Pin 6 Logic 1
Inhibit	Outputs OFF	Outputs OFF
Enable	Outputs ON	Outputs ON

Logic 0 = 0-0.8V. Logic 1 = 2.0 - 5.0V with respect to 0V (Pin 3)

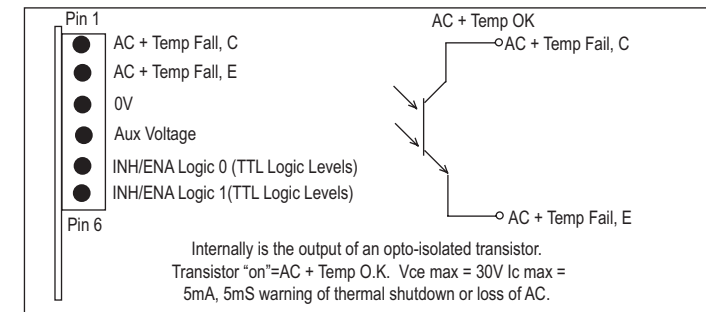

Input Filter Options		
Option	Max. Leakage at 264VAC, 63Hz	RFI EN55022 Class:
Standard	1.5mA max	B
L	290uA max	A

Note: When primary options EW or FW are fitted the above values increase by 100uA

Secondary Options

Remote Sense Option

SINGLE Output Module "N" Option

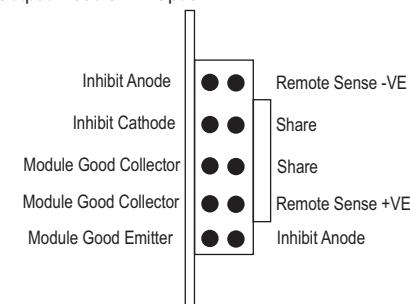

Inhibit

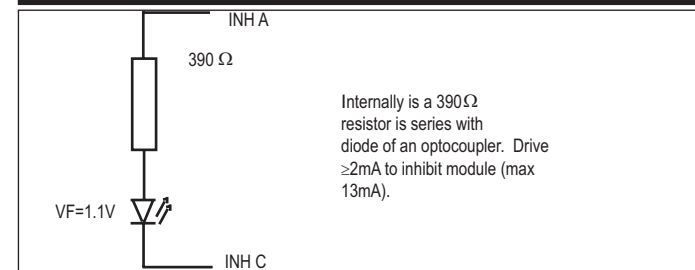

Module Good

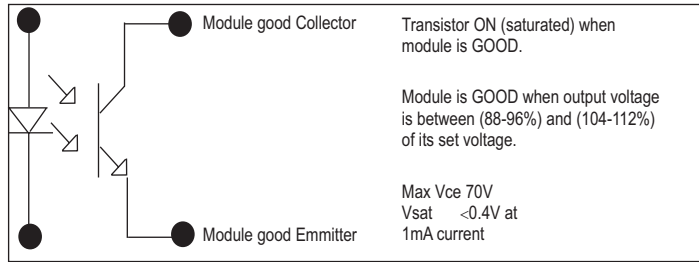

TWIN Output Module "N" Option

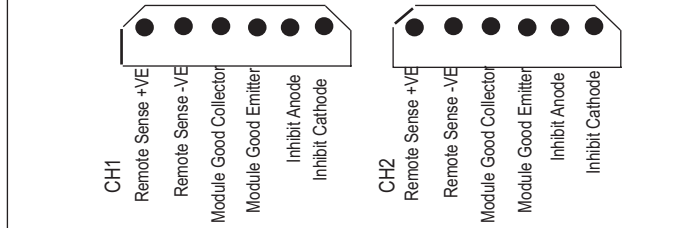

Customer fixings

Right Angle Screw Terminal Input

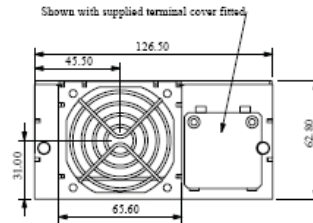
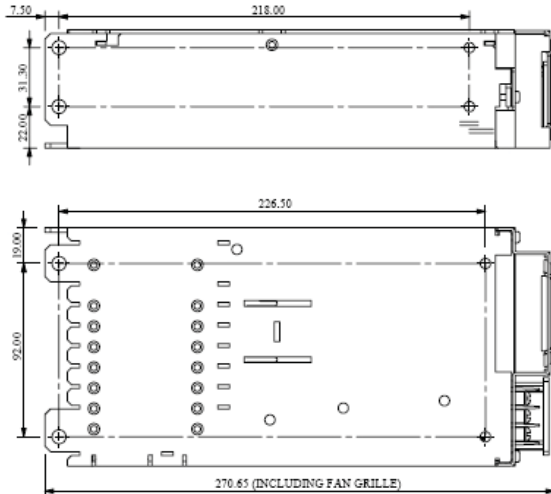

Customer fixings are M4

CEL Part No. 17161 Issue 5 March 2008



Coutant Lambda Limited,
Kingsley Avenue,
Ilfracombe,
Devon, EX34 8ES.
Telephone - Sales and Service (01271) 856666.
Head Office and Works (01271) 856600.
Facsimile (01271) 864894.
WEBSITE: www.lambda-gb.com