



Alpha

400, 600, 1000 & 1500 Watts Modular

- Up to 1500W output
- Up to 16 outputs
- Voltages up to 48V, Current up to 300 Amps
- Fast-on output connection
- Worldwide approvals & CB report
- Medical Approval Option
- 3 Year Warranty

Key Market Segments & Applications

Instrumentation

Broadcast

Medical

ATE

Automation

Industrial Computing

Security

Lifesciences/Laboratory

Network Servers and Routers

INPUT	
Input Voltage	Alpha 400 90 - 264Vac Alpha 600 90 - 264Vac, 160 - 358Vdc Alpha 1000 85 - 264Vac, 120 - 360Vdc Alpha 1500 85 - 264Vac (1000W below 150Vac input)
Input Frequency	47 - 63Hz (440Hz with reduced PFC - consult factory)
Inrush Current	<50A at 25°C and 264Vac (cold start)
Input Fuse	250Vac HBC Fast Acting (not user accessible) 10A for 400W 12A for 600W 20A for 1000W and 1500W
Leakage Current	1.1mA max at 264Vac & 63Hz
Lower Leakage Option	see configuring guide
Power Factor	0.99 typical

OUTPUT	
Voltage / Current	See module output table
Turn on Delay	1.5s max at 90Vac (150Vac for Alpha 1500W) & 100% rated output power
Rise Time	<50ms to 90% of voltage, monotonic rise above 10%
Turn on Overshoot	<5% or 250mV Load type dependant, no overshoot with resistive load
Efficiency	75% typical at 230Vac & 100% rated power, config dependent
Hold up	15ms min at 90Vac & 100% rated output power 13ms for 1000W, 8ms for 1500W and at 207Vac for 1500W
Ripple & Noise	<2% (or 100mV if greater) Pk- Pk, using EIAJ test method & 20MHz bandwidth
Voltage Accuracy	<1% of set Voltage
Remote Sense	Yes Standard on single output modules
Minimum Load	No on any output
Temperature Coefficient	<0.02% of rated voltage per °C
Load Regulation	<0.5% or 25mV for 0-100% load change (with sense connected, <2% without)
Line Regulation	<0.5% for 90 - 264Vac input change (210-264Vac for 1500W)
Cross Regulation	<0.2% for 100% load change on any other output
Transient Response	<10% of set voltage for 50% load change (above 25% load)
Recovery	500µs for recovery to 1% or 100mV of set voltage (1000µs for S module)
Over Voltage Protection	Standard for all outputs
Over Current Protection	Standard for all outputs
Short Circuit Protection	<150% of rated current, when output voltage <1%
Over Temperature Protection	Yes Shuts down all outputs. Cycle ac off / on to reset
	Note shutdown temp varies according to ambient, output power and input V

SAFETY APPROVALS					
	Date	Amendments		Date	Amendments
EN 60950-1	2001		IEC 60601-1 _a	1988	A1, A2
UL 60950-1	2003		UL 60601-1 _a	2003	
CSA22.2 No 60950-1	2003		CSA 60601-1 _a	2003	
IEC60950-1*	2001		CE Mark	LV Directive 2006/95/EC (EN60950-1)	
* CB Certificate and report available on request			a - Only for LL, RL and TL leakage variants. CA400 + CA1000 only		

PRODUCT, GENERIC & COLLATERAL STANDARDS			
Low Voltage Power Supply, EMC	EN61204-3: 2001	Compliant to High Severity Immunity	Class A emissions for CA1000 / CA1500
Medical Electrical Equipment, EMC	EN61601-1-2: 2001	Compliant	Class A emissions for CA1000 / CA1500
Immunity for residential, commercial and light industrial environments	EN61000-6-1: 2001	Compliant	
Immunity for industrial environments	EN61000-6-2: 2001	Compliant	
Emissions for residential, commercial and light industrial environments	EN61000-6-3: 2001	Compliant	CA1000 and CA1500 not compliant
Emissions for industrial environments	EN61000-6-4: 2001	Compliant	

EMISSIONS			
Radiated Electric Field	EN55022	Class B (as per CISPR.22) Class A for Alpha 1000/1500	See application note for details. Only for 'S' type leakage versions
Conducted Emissions	EN55022	Class B (as per CISPR.22) Class A for Alpha 1000/1500	Only for 'S' type leakage versions. 'M' & 'L' types meet Class A
Conducted Harmonics	EN61000-3-2: 2001	Compliant to Class A	
Flicker	EN61000-3-3: 1995 + A1:2001	Compliant - d _{max} only.	

IMMUNITY				
				Criteria
Electrostatic Discharge	EN61000-4-2	Level 4	Air discharge 15kV Contact discharge 8kV	A
Electromagnetic Field	EN61000-4-3	Level 3	10V/m (tested to 12V/m)	A
Fast / Burst Transient	EN61000-4-4	Level 4	Input 4kV Outputs 2kV, Tested at 5kHz and 100kHz	A
Surge Immunity	EN61000-4-5	Level 3	Line to Line (Differential) 1.1kV Line to Earth (Common Mode) 2.2kV	A
Conducted RF Immunity	EN61000-4-6	Level 3	10V (tested to 12V)	A
Power Frequency Magnetic Field	EN61000-4-8	Level 4	30A Continuous	A
Voltage Dips, Variation, Interruptions	EN61000-4-11	Class 3		A B for 5s interruptions
Voltage Fluctuations	EN61000-4-14	Class 3	For 100 to 240V nominal	A

ENVIRONMENT	
Temperature	0°C to 70°C operational, -40° to 85°C storage (max 12 months)
Derating	50°C to 70°C derate each output by 2.5% per °C
Low Temperature Start-up	-20°C
Humidity	5-95% RH non condensing
Shock	3000 shocks, each of 10g (16ms) half sine
Vibration	10 - 200Hz @ 1.5g
Altitude	3,000 metres operational (15,000 metres non operational)
Pollution	Degree 2, Material group 3
IP Rating	IP 10

ISOLATION					
Input to Output	Reinforced	4.3 kV (dc)	Output to Earth	Operational	500 V (dc)
Input to Earth	Basic	2.3 kV (dc)	Output to Output	Operational	500 V (dc)

OUTPUT VOLTAGES (single output modules)				(twin output modules)					
Module	Adjustment Range (Volts)	Amps	Slots	Module	V1 Adjustment Range (Volts)	Amps	V2 Adjustment Range (Volts)	Amps	Slots
A	4.5 - 5.5	60	2	E	5 - 16	8	5 - 16	8	1
AA	4.5 - 6.5	60	2	EB	4.5 - 5.5	9	4.5 - 5.5	9	1
B	4.5 - 5.5	25	1	EQ	4.5 - 5.5	9	2.7 - 3.9	9	1
BB	4.5 - 6.5	25	1	H	18 - 32	5	18 - 32	5	1
C	5 - 16	16 _a	1	P	18 - 29	5	5 - 16	8	1
D	18 - 29	8	1						
F	9 - 16	33	2						
G	17.5 - 29	25 _b	2						
J	30 - 48	10 _c	2						
K	18 - 29	15	2						
L	1.8 - 3.2	25	1						
M	5 - 16	8	1						
N	18 - 32	5 _d	1						
Q	2.7 - 3.9	25	1						
R	2.7 - 3.9	60	2						
S	2.5 - 5.7	85	2						
T	1.8 - 3.2	60	2						
U	10 - 21	16	1						
W	4.5 - 5.5	15	1						
Z	4.5 - 5.5	25	1						

a) 12A max above 12V
b) 21A max above 24.5V
c) Derate output current by 0.25A / V above 40V
d) 1A max above 29V

Alpha Configuring Guide

The extensive range of output modules and options make it possible to achieve many combinations of Volts and Amps. To achieve the optimum configuration, please contact our sales office. However you can also create your own configuration from this datasheet by using the guide below.

Configuring from Datasheet

- 1 Calculate total output power to determine Alpha 400W, 600W, 1000W or 1500W and select converter, then select required Cooling and Leakage Current from the following table:-

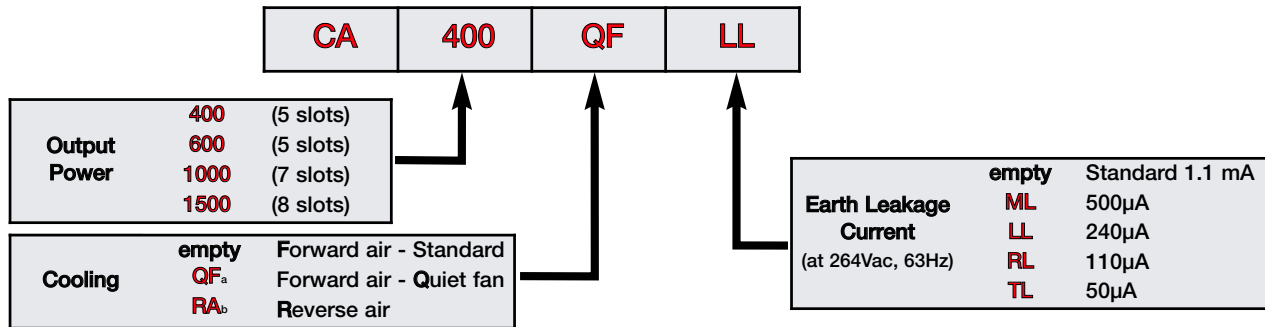

Notes:

- CA400/600 only. CA400 derates to 300W, CA600 derates to 475W
- Contact sales office for details

- 2 Select Output Modules and Options from the Output Voltages tables.

Example - if you require 5.2V / 18A with output inhibit :-

- select B as closest match for voltage and current and prefix with voltage (e.g. **5.2B**)
- add suffix for option (if required)
 - '_PA' for parallel/current share (for N+1 redundant applications)
 - '_PP' for parallel (increase current from one PSU)
 - '_IN' for inhibit
 - '_RP' for remote programming
 - '_MF' (only applicable on 1st module) for global inhibit, ac fail and 5V/50mA standby supply
- repeat for other outputs

Ensure that the total width of all selected modules is within the slots for the chosen converter. For example:-

CA600LL 5A 12/12E 24D which represents a four output 600W Alpha with Forward air, 240µA Earth Leakage, with:-

- Output 1 = 5V / 60A with remote sense
- Output 2 = 12V / 8A
- Output 3 = 12V / 8A
- Output 4 = 24V / 8A with remote sense

- 3 Contact Lambda to validate configuration and issue a part number.

Option Connections

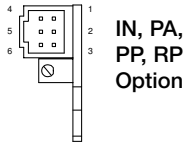

Pin	IN option	PA option	PP option	RP option	MF option
1	n/c	+ Sense	+ Sense	+ Sense	Inhibit (low)
2	Module Good	Module Good	n/c	- Sense	5V supply
3	Inhibit	Star point	n/c	Control 2	Power Fail
4	n/c	- Sense	- Sense	n/c	0V
5	- Power	- Power	n/c	Control 1	Inhibit (high)
6	- Power	Star point	n/c	n/c	n/c

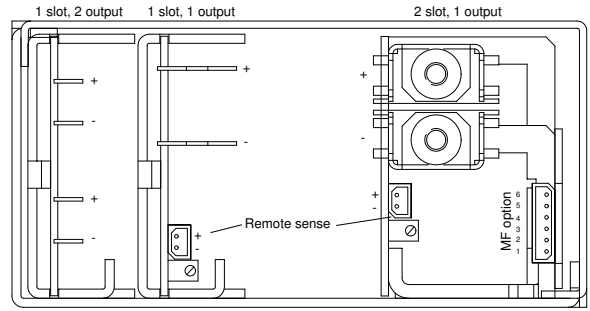

Alpha 400

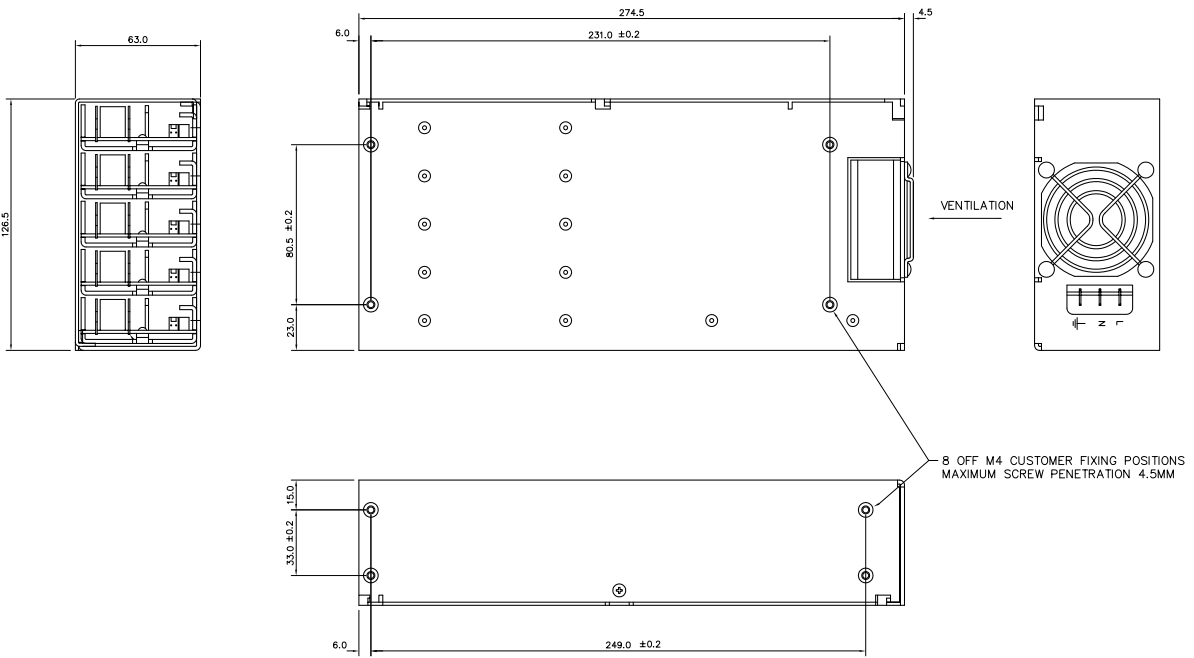

Alpha 600

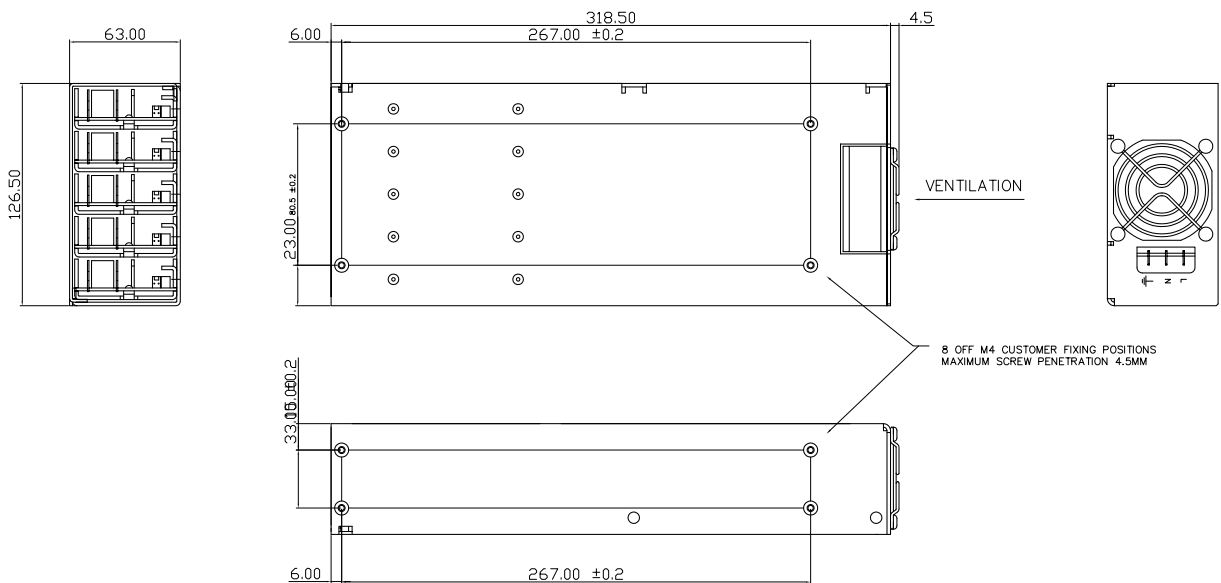

Alpha 1000

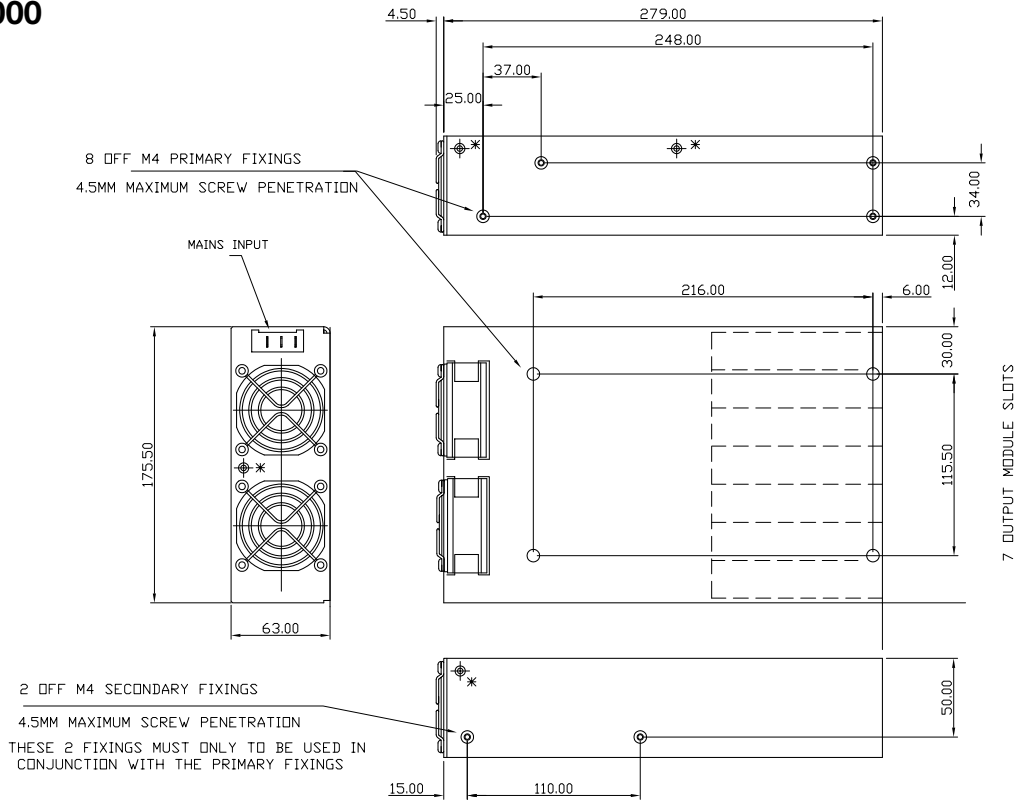

Alpha 1500

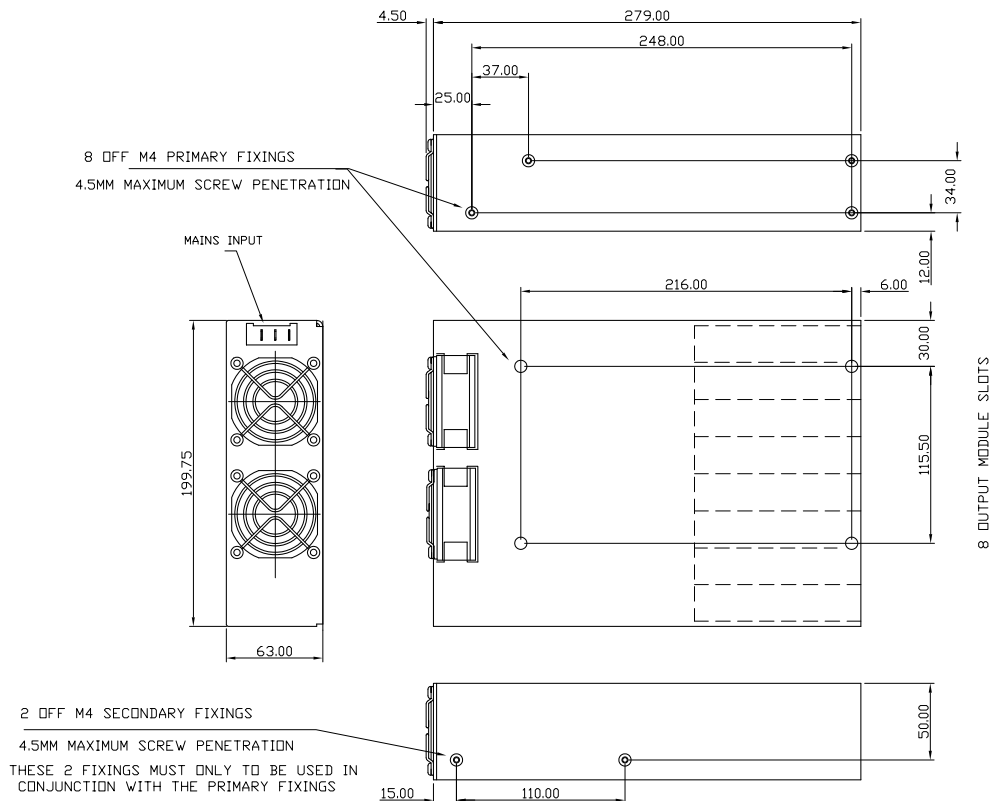

LAMBDA EMEA

AUSTRIA LAMBDA ELECTRONICS GmbH Aredstraße 22 A-2544 Leobersdorf	Telephone: +43 (0) 2256 655 84 Facsimile: +43 (0) 2256 645 12 Web: www.lambda-austria.com
FRANCE LAMBDA SAS ZAC des Delaches, BP1077 - Gometz le Chatel 91940 Les Ulis	Telephone: +33 (0) 1 60 12 71 65 Facsimile: +33 (0) 1 60 12 71 66 Web: www.lambda-f.com
GERMANY LAMBDA GmbH Karl-Bold-Straße 40 D-77855 Achern	Telephone: +49 (0) 78 41 666 0 Facsimile: +49 (0) 78 41 5000 Web: www.lambda-germany.com
ISRAEL NEMIC LAMBDA LTD Kibbutz Givat Hashlosa 48800	Telephone: +972 (0) 3 902 4333 Facsimile: +972 (0) 3 902 4777 Web: www.nemic.co.il
ITALY LAMBDA s.r.l. Via dei Lavoratori 128/130, 20092, Cinisello Balsamo (Mi)	Telephone: +39 (0) 02 61 29 38 63 Facsimile: +39 (0) 02 61 29 09 00 Web: www.lambda-italy.com
SWEDEN LAMBDA SCANDINAVIA PO Box 546, Rallervägen 41 SE-184 25. Åkersberga	Telephone: +46 (0) 8 598 94 090 Facsimile: +46 (0) 8 540 66 096 Web: www.lambda-scandinavia.com
UK LAMBDA UK Kingsley Avenue Ilfracombe Devon EX34 8ES	Telephone: +44 (0) 1271 856666 Facsimile: +44 (0) 1271 864894 Web: www.lambda-gb.com

LAMBDA NORTH AMERICA

visit www.lambdapower.com for a list of Lambda offices and distributors

LAMBDA ASIA

visit www.densei-lambda.com for a list of Lambda offices and distributors

LOCAL DISTRIBUTION