



Vega

450, 650 & 900 Watts Modular

- Industry Leading Power Density
- Up to 11 outputs
- Voltages up to 62V, Current up to 114 Amps
- Screw, Fast-on or IEC connection
- Worldwide approvals & CB report
- Medical Approval Option
- 3 Year Warranty

Key Market Segments & Applications

Instrumentation

Broadcast

Medical

ATE

Automation

Industrial Computing

Security

Lifesciences/Laboratory

Network Servers and Routers

INPUT

	Vega 450, 650, and 900	Vega dc (450W)
Input Voltage	90 - 264Vac 900W version is 150-264Vac only, 650W below 150Vac	34 - 75Vdc Derate linearly below 44V to 340W at 34V
Input Frequency	47 - 63Hz (440Hz with reduced PFC - consult factory)	dc only
Inrush Current	<40A at 25°C and 264Vac (cold start)	<40A at 25°C, ETSI EN300 132-2
Input Fuse	16A / 250Vac HBC Fast Acting (not user accessible)	20A Fast Acting (not user accessible)
Leakage Current	1.5mA max at 264Vac & 63Hz	n/a
Lower Leakage Option	see configuring guide	n/a
Power Factor	0.99 typical	n/a

OUTPUT

Voltage / Current	See module output table	
Turn on Delay	1.5s max	at 90Vac (150Vac for 900W, 48Vdc for Vega dc) & 100% rated output power
Rise Time	<50ms	to 90% of voltage, monotonic rise above 10%
Turn on Overshoot	<5% or 250mV	Load type dependant, no overshoot with resistive load
Efficiency	75%	typical at 230Vac (48Vdc for Vega dc) & 100% rated power, config dependent
Hold up	16ms min	at 90Vac (150Vac for 900W) & 100% rated output power. 10ms min for Vega dc
Ripple & Noise	<1% or 50mV	Pk- Pk, using EIAJ test method & 20MHz bandwidth
Voltage Accuracy	<1%	of set Voltage
Remote Sense	Yes	Standard on single output modules, max 0.75V total line drop Option for twin output modules
Minimum Load	No	on any output
Temperature Coefficient	<0.02%	of rated voltage per °C
Load Regulation	<0.5% or 25mV	for 0-100% load change
Line Regulation	<0.1%	for 90 - 264Vac input change (34-75Vdc for Vega dc)
Cross Regulation	<0.2%	for 100% load change on any other output
Transient Response Recovery	<6% or 300mV 500µs	of set voltage for 50% load change (above 25% load) for recovery to 1% or 100mV of set voltage
Over Voltage Protection	120 - 130% 140 - 150% 120 - 150%	of set voltage for outputs > 4.1V (Tracking OVP) of set voltage for outputs < 4.1V (Tracking OVP) of max rated output (Fixed OVP)
Over Current Protection	105 - 125%	of rated current, constant current characteristic
Short Circuit Protection	<150%	of rated current, when output voltage <1%
Over Temperature Protection	Yes	Shuts down all outputs and fan. Cycle ac off / on to reset Note 1 shutdown temp varies according to ambient, output power and input V 2 ac fail signal (if fitted) provides 5ms warning of thermal shutdown

SAFETY APPROVALS

	Date	Amendments		Date	Amendments
EN 60950-1	2006		EN 61010-1	2001	
UL 60950-1	2003		IEC 61010-1*	2001	
CSA22.2 No 60950-1	2003		IEC 60601-1* _a	1988	A1, A2
IEC60950-1*	2005		EN 60601-1 _a	1990	A1, A2, A13
CE Mark	LV Directive 2006/95/EC (EN60950-1)		UL 60601-1 _a	2003	with revisions 2006
* CB Certificate and report available on request			a - Only for L, R and T leakage variants. Not applicable to Vega dc		

EMISSIONS BS EN61000-6-3:2001 (Residential, Commercial & Light Industrial Supply), also complies with BS EN61000-6-4:2001

Radiated Electric Field	EN55022	Class B (as per CISPR.22) Class A for Vega dc	See application note for details. Only for 'S' type leakage versions
Conducted Emissions	EN55022	Class B (as per CISPR.22) Class A for Vega dc	Only for 'S' type leakage versions. 'M' & 'L' types meet Class A
Conducted Harmonics	EN61000-3-2	Compliant to Class A	Not applicable to Vega dc
Flicker	EN61000-3-3	Compliant	Not applicable to Vega dc

IMMUNITY BS EN61000-6-2:2001 (Industrial Environment), also complies with BS EN61000-6-1:2001

				Criteria
Electrostatic Discharge	EN61000-4-2	Level 4	Air discharge 15kV Contact discharge 8kV	A
Electromagnetic Field	EN61000-4-3	Level 3	10V/m (tested to 12V/m)	A
Fast / Burst Transient	EN61000-4-4	Level 4 Level 3 for Vega dc	Input 4kV, (2kV for Vega dc) Outputs 2kV, (1kV for Vega dc) Tested at 5kHz and 100kHz	A
Surge Immunity	EN61000-4-5	Level 3 Level 2 for Vega dc	Line to Line 1kV tested to 1.1kV (0.5kV, tested to 0.55kV for Vega dc) Line to Earth 2kV tested to 2.2kV (1kV, tested to 1.1kV for Vega dc)	A
Conducted RF Immunity	EN61000-4-6	Level 3	10V (tested to 12V)	A
Power Frequency Magnetic Field	EN61000-4-8	Level 4	30A Continuous	A
Voltage Dips, Variation, Interruptions	EN61000-4-11	Class 3 na - Vega dc		A B for 5s interruptions

ENVIRONMENT

Temperature	0° to 65° operational, -25° to 85°C storage (max 12 months)
Derating	50°C to 65°C derate each output by 2.5% per °C (1.5% per °C for Vega dc)
Low Temperature Start-up	-20°C
Humidity	5-95% RH non condensing
Shock	±3 x 20g shocks in each plane, total 18 shocks 20g shock = 11ms (±0.5ms), half sine conforms to EN60068-2-27, EN60068-2-47, IEC68-2-27, IEC68-2-47, JIS C0041-1987 conforms to MIL-STD-810E/F, Method 514.4, Pro I, Cat 1, 9
Vibration	Single axis 10 - 500Hz at 2g (sweep and endurance at resonance) in all 3 planes Conforms to EN60068-2-6, IEC68-2-6 Conforms to MIL-STD-810E, Method 516.5, Pro I, IV, VI
Altitude	5000 metres operational / non operational (IEC inlet 3000m operational, 5000m non-operational)
Pollution	Degree 2, Material group 3
IP Rating	IP 10

ISOLATION

Input to Output	Reinforced	4.3 kV (dc)	Output to Earth	Operational	200 V (dc)
Input to Earth	Basic	2.3 kV (dc)	Output to Output	Operational	200 V (dc)

OUTPUT VOLTAGES (single output modules)					(twin output modules)							
Module	Adjustment Range (Volts)		Amps	Slots	Module	V1 Adjustment Range (Volts)	Amps	V2 Adjustment Range (Volts)	Amps	Slots		
B1L	1.8	- 3.8 _e	20	1	H1L/1L	1.8 - 3.8 _n	12	1.8 - 3.8 _n	8	1		
C1	1.8	- 4.1 _e	35	1	H1L/1H			3.9 - 5.5 _d	8	1		
C1Y	1.8	- 4.1 _e	40	1	H1L/2			5.6 - 9 _f	6	1		
D1L	1.8	- 3.8 _e	50	1.5	H1L/3			9.1 - 16.2 _u	6	1		
E1	1.8	- 3.8 _e	60	2	H1L/4	3.9 - 5.5 _d	12	16.3 - 25 _p	4.5	1		
F1 _a	1.8	- 3.8	80	2	H1H/1L			1.8 - 3.8 _n	8	1		
Z2	1.8	- 3.8 _e	95	3	H1H/1H			3.9 - 5.5 _d	8	1		
Z3	1.8	- 3.8 _e	114	4	H1H/2			5.6 - 9 _f	6	1		
B1H	3.9	- 5.5 _d	20	1	H1H/3	5.6 - 9 _f	10	9.1 - 16.2 _u	6	1		
L1	4.2	- 5.5 _d	35	1	H1H/4			16.3 - 25 _p	4.5	1		
D2	3.8	- 9 _k	45	1.5	H2/1L			1.8 - 3.8 _n	8	1		
D1H	3.9	- 5.5 _d	50	1.5	H2/1H			3.9 - 5.5 _d	8	1		
E2	3.8	- 8 _k	60	2	H2/2	9.1 - 16.2 _u	10	5.6 - 9 _f	6	1		
Z18	4.2	- 5.5	66	2	H2/3			9.1 - 16.2 _u	6	1		
F2 _a	3.8	- 8	75	2	H2/4			16.3 - 25 _p	4.5	1		
Z4	3.9	- 5.5 _d	95	3	H3/1L			1.8 - 3.8 _n	8	1		
Z6	3.9	- 5.5 _d	104	3.5	H3/1H	16.2 - 28	5	3.9 - 5.5 _d	8	1		
B2	5	- 9 _f	25	1	H3/2			5.6 - 9 _f	6	1		
B3	9.1	- 16.2 _g	12	1	H3/3			9.1 - 16.2 _u	6	1		
C3	9.1	- 16.2 _g	18	1	H3/4			16.3 - 25 _p	4.5	1		
D3	8	- 16.5 _g	24	1.5	H5/1L	16.2 - 28	5	1.8 - 3.8 _n	8	1		
E3L	8	- 13.9 _l	40	2	H5/1H			3.9 - 5.5 _d	8	1		
Z7	8	- 16.5 _g	45	3	H5/2			5.6 - 9 _f	6	1		
EE2	7.6	- 16 _g	45	4	H5/3			9.1 - 16.2 _u	6	1		
D4	14	- 21.5 _i	18	1.5	H5/4	16.3 - 25 _p	4.5	16.3 - 25 _p	4.5	1		
E4	14	- 19.9 _m	30	2	Wide Range Programmable Modules							
E3H	14	- 15	36	2	Module			Voltage Range	Amps	Slots		
C4	16.3	- 21.5 _i	14	1	W2 _a			1 - 7.5	30	1	Select features from table below	
CC3	18.2	- 32.4 _j	18	2	W5	0.5 - 32	8.5	1				
E5L _o	20	- 24	27	2	Follow by	F or T Fixed or Tracking Overvoltage protection						
B5	21.6	- 31 _h	6	1		F or S Fast-on or Screw terminal						
C5	21.6	- 31 _j	10	1		R or V Resistance (0-32kOhm)						
D5	21	- 28	15	1.5		Voltage (0-5V) programming						
E5H _o	24	- 28	25	2		1 Inhibit, Fixed Current Limit						
Z19 _{co}	24	- 28	36	3.5		1, 2, 3 2 Inhibit, Programmable current limit (0-5V)						
HH5/3	25.3	- 44.2 _b	5	1		or 4 3 Enable, Fixed Current Limit						
DD4	28	- 43 _s	18	3		4 Enable, Programmable current limit (0-5V)						
EE4 _c	28	- 38	22.5	4								
HH5/4	32.5	- 53 _t	4.5	1								
BB4	32.6	- 43 _q	10	2	Follow non wide range modules by F (Fast-on) or S (Screw) terminal							
EE5L _{co}	40	- 48	18	4	Options - Single output Modules*			Options - Twin Output Modules*				
C5B4	43	- 48	10	2	N	Output Inhibit, Module Good Current Sharing			N	Output Inhibit, Module Good, Remote Sense		
EE5H _o	48	- 56	18	4					R	Remote sense only		
CC5	48.1	- 62 _r	10	2								
DD5	42	- 56	15	3	* see configuring guide							

- a) F1, F2 and W2 modules not for Vega 900
- b) 38V max for 900W
- c) Only available for Vega 900
- d) 5.1V max for 900W
- e) 3.4V max for 900W
- f) 8V max for 900W
- g) 15V max for 900W

- h) 28V max for 900W
- i) 18V max for 900W
- j) 30V max for 900W
- k) 7.5V max for 900W
- l) 12.5V max for 900W
- m) 19V max for 900W
- n) 3.4V max for 900W

- o) 'N' option not available
- p) 24V max for 900W
- q) 40V max for 900W
- r) 60V max for 900W
- s) 36V max for 900W
- t) 52V max for 900W
- u) 15.5V max for 900W

Vega Configuring Guide

The extensive range of output modules and options make it possible to achieve almost any combination of Volts and Amps. The 'online' configurator is the best way to achieve the optimum configuration, however you can also create your own Vega configuration from this datasheet by using the guide below.

Web Configurator

- 1 Visit <http://www.lambda-gb.com>, select 'Vega Configurator' and follow the online instructions.
- 2 Enter your required Volts / Amps, type of output connection and any additional functions (if required)
- 3 Enter preferred type of cooling, input connection, lower leakage current (if required) and controls & signal functions, (if required)
- 4 Configurator will select the most suitable modules and options and give a unique part number.

Configuring from Datasheet

- 1 Calculate total output power to determine Vega 450W, 650W or 900W and select converter, then select required Cooling, Connection, Leakage Current and Controls/Signals from the following table:-

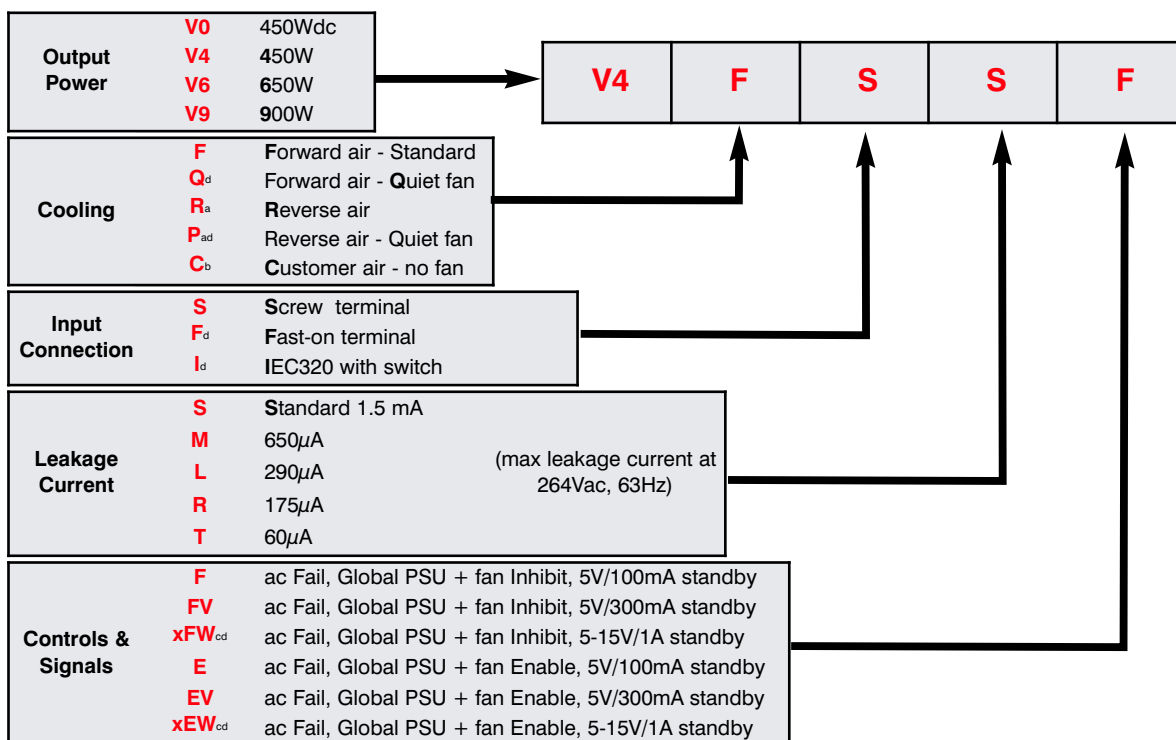

Notes:

- a) Not available for Vega 900
 - b) Thermocoupled sample recommended to ensure adequate cooling - consult sales
 - c) xFW and xEW options increase leakage current by 90µA
Replace 'x' with required output voltage (5FW = 5V aux supply)
 - d) Not available for Vega dc.
- 2 Select Output Modules and Options from the Output Voltages tables.
Example - if you require 5.2V / 18A with output inhibit :-
 - a) select B1H as closest match for voltage and current and prefix with voltage (eg **5.2B1H**)
 - b) add suffix S or F for Screw or Fast-on connection (eg **5.2B1HS**)
 - c) add suffix N for output inhibit eg **5.2B1HSN**
 - d) repeat for other outputs

Ensure you do not select more than a total of 5 slots width of module. This will create a complete product description eg:-
V6FSSSF 5L1S 12/12H3/3S 24C5S which represents a four output 650W Vega with Forward air, Screw input terminals, 1.5mA Earth Leakage, ac Fail, Global Inhibit & 5V / 100mA aux supply with the following outputs:-

- Output 1 = 5V / 35A with output inhibit, Module Good and Current Share option
- Output 2 = 12V / 10A
- Output 3 = 12V / 6A
- Output 4 = 24V / 10A

- 3 Contact Lambda to validate configuration and issue a part number.

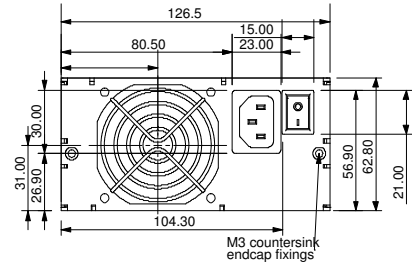
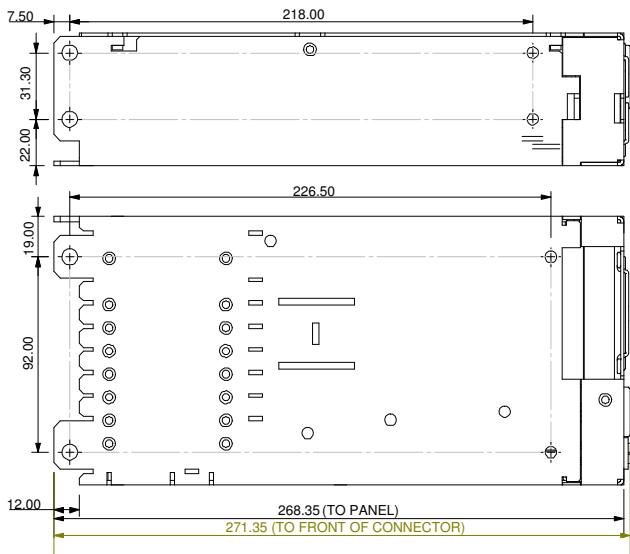

IEC-320 Connector Case

All versions have:-
 8 x M4 Customer fixings
 Max thread penetration:- 4.5mm

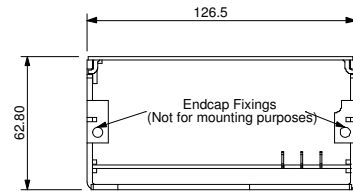
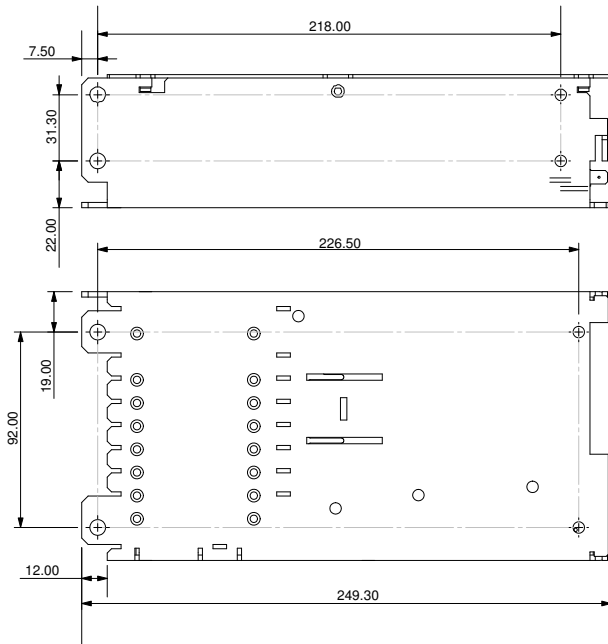

Customer Air Case (no fan)

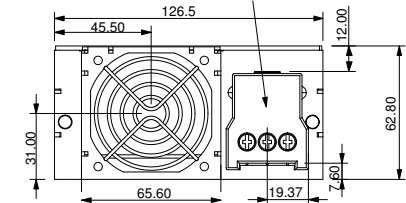
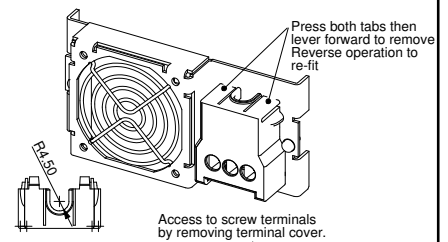
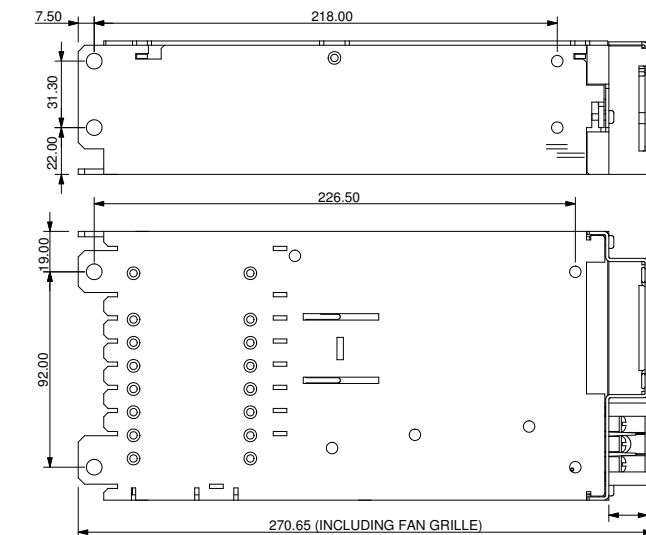

Screw & Fast-on Terminal Case

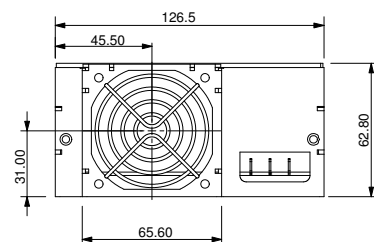

LAMBDA EMEA

AUSTRIA	
LAMBDA ELECTRONICS GmbH Aredstraße 22 A-2544 Leobersdorf	Telephone: +43 (0) 2256 655 84 Facsimile: +43 (0) 2256 645 12 Web: www.lambda-austria.com
FRANCE	
LAMBDA SAS ZAC des Delaches, BP1077 - Gometz le Chatel 91940 Les Ulis	Telephone: +33 (0) 1 60 12 71 65 Facsimile: +33 (0) 1 60 12 71 66 Web: www.lambda-f.com
GERMANY	
LAMBDA GmbH Karl-Bold-Straße 40 D-77855 Achern	Telephone: +49 (0) 78 41 666 0 Facsimile: +49 (0) 78 41 5000 Web: www.lambda-germany.com
ISRAEL	
NEMIC LAMBDA LTD Kibbutz Givat Hashlosha 48800	Telephone: +972 (0) 3 902 4333 Facsimile: +972 (0) 3 902 4777 Web: www.nemic.co.il
ITALY	
LAMBDA s.r.l. Via dei Lavoratori 128/130, 20092, Cinisello Balsamo (Mi)	Telephone: +39 (0) 02 61 29 38 63 Facsimile: +39 (0) 02 61 29 09 00 Web: www.lambda-italy.com
SWEDEN	
LAMBDA SCANDINAVIA PO Box 546, Rallervägen 41 SE-184 25. Åkersberga	Telephone: +46 (0) 8 598 94 090 Facsimile: +46 (0) 8 540 66 096 Web: www.lambda-scandinavia.com
UK	
LAMBDA UK Kingsley Avenue Ilfracombe Devon EX34 8ES	Telephone: +44 (0) 1271 856666 Facsimile: +44 (0) 1271 864894 Web: www.lambda-gb.com

LAMBDA NORTH AMERICA

visit www.lambdapower.com for a list of Lambda offices and distributors

LAMBDA ASIA

visit www.densei-lambda.com for a list of Lambda offices and distributors

LOCAL DISTRIBUTION